

## **Description and simulation of a physiological pharmacokinetic model for the metabolism and enterohepatic circulation of bile acids in man. Cholic acid in healthy man.**

A F Hofmann, ... , M Milanese, G Belforte

*J Clin Invest.* 1983;71(4):1003-1022. <https://doi.org/10.1172/JCI110828>.

### Research Article

A multicompartamental pharmacokinetic model based on physiological principles, experimental data, and the standard mathematical principles of compartmental analysis has been constructed that fully describes the metabolism and enterohepatic cycling in man of cholic acid, a major bile acid. The model features compartments and linear transfer coefficients. The compartments are aggregated into nine spaces based on physiological considerations (liver, gallbladder, bile ducts, jejunum, ileum, colon, portal blood sinusoidal blood, and general circulation). The transfer coefficients are also categorized according to function: flow, i.e., emptying of gallbladder or intestinal spaces, and circulation of the blood; biotransformation, i.e., conjugation, deconjugation, or dehydroxylation; and transport, i.e., active or passive transport. The model is made time dependent by introducing meals, which trigger discrete increases in gallbladder emptying and intestinal flow. Each space contains three compartments. For cholic acid, these are unconjugated cholic acid, cholyglycine, and cholytaurine. The model was then used with all existing experimental data to simulate cholic acid metabolism in healthy man over a 24-h period. Satisfactory agreement was obtained between simulated and experimental results for serum bile acid levels, hepatic bile acid secretion, and bile acid secretion into the intestine. The model was also used to classify 16 clinical instances in which the enterohepatic circulation of bile acids is altered by drugs or disease. The model can be extended to describe completely [...]

**Find the latest version:**

<https://jci.me/110828/pdf>



# Description and Simulation of a Physiological Pharmacokinetic Model for the Metabolism and Enterohepatic Circulation of Bile Acids in Man

## CHOLIC ACID IN HEALTHY MAN

A. F. HOFMANN, *Division of Gastroenterology, Department of Medicine, University of California at San Diego, San Diego, California 92103*

G. MOLINO and M. MILANESE, *Istituto di Medicina Interna, Clinica Medica II, Università di Torino, Italy*

G. BELFORTE, *Centro di Elaborazione Numerale dei Segnali, Istituto di Elettrotecnica, Politecnico di Torino, Italy*

**ABSTRACT** A multicompartimental pharmacokinetic model based on physiological principles, experimental data, and the standard mathematical principles of compartmental analysis has been constructed that fully describes the metabolism and enterohepatic cycling in man of cholic acid, a major bile acid. The model features compartments and linear transfer coefficients. The compartments are aggregated into nine spaces based on physiological considerations (liver, gallbladder, bile ducts, jejunum, ileum, colon, portal blood, sinusoidal blood, and general circulation). The transfer coefficients are also categorized according to function: flow, i.e., emptying of gallbladder or intestinal spaces, and circulation of the blood; biotransformation, i.e., conjugation, deconjugation, or dehydroxylation; and transport, i.e., active or passive transport. The model is made time dependent by introducing meals, which trigger discrete increases in gallbladder emptying and intestinal flow. Each space contains three compartments. For cholic acid, these are unconjugated cholic acid, cholyglycine, and cholytaurine. The model was then used with all existing experimental data to simulate cholic acid metabolism in healthy man over a 24-h period. Satisfactory agreement was obtained between simulated and experimental results for serum bile acid levels, hepatic bile acid secretion, and bile acid secretion into the intestine. The model was also used to classify 16 clinical instances in which the enterohepatic circulation of bile acids is altered

by drugs or disease. The model can be extended to describe completely the metabolism and enterohepatic circulation of any bile acids in man in health and digestive disease. The model should also be broadly applicable to the description of the pharmacokinetics of all other drugs whose metabolism is similar to that of bile acids, i.e., drugs for which there are tissue and bacterial biotransformations, enterohepatic cycling, and appreciable first-pass clearance.

## INTRODUCTION

The physiological importance of bile acids as water-soluble end products of cholesterol metabolism and as amphipathic compounds that enhance cholesterol excretion and lipid absorption by the formation of mixed micelles is well established (1, 2). More recently, the two 3,7-dihydroxy bile acids, chenodeoxycholic and ursodeoxycholic acids, have been shown to have useful pharmacological activity, since, when administered chronically, they induce cholesterol gallstone dissolution in man (3, 4). Serum bile acid levels have also been used to detect intestinal (5) or hepatic disease (6). In principle, therefore, bile acid metabolism should be of interest to the physiologist, pharmacologist, gastroenterologist, and clinical chemist.

Early studies of bile acid metabolism have been summarized by Josephson (7). Modern studies on bile acid metabolism may be considered to begin with Bergstrom and his colleagues, who synthesized 24-<sup>14</sup>C-labeled bile acids and defined their metabolism in animals (8). Lindstedt (9), a member of this research group, prepared radioactive cholic acid and showed

---

*Received for publication 21 July 1982 and in revised form 8 December 1982.*

that the overall metabolism of cholic acid in man could be described by a single well mixed compartment. He defined the exchangeable pool size and the fractional turnover rate and calculated the daily synthesis rate.

Lindstedt's pioneering work was extended by other investigators who showed that the metabolism of the other primary bile acid, chenodeoxycholic acid (10, 11), and the major secondary bile acid, deoxycholic acid (12, 13), could also be described by a single compartmental model. This work was further extended by a series of studies from the Mayo Clinic that defined the metabolism in healthy man of bile acids labeled in both the steroid and amino acid moieties (12, 14, 15). These studies showed that the turnover of the steroid moiety, especially for glycine-conjugated bile acids, was slower than that of the amino acid moiety. The data were used to propose a multicompartmental model (16) that encompassed synthesis, conjugation, deconjugation, reconjugation, and dehydroxylation. The multicompartmental model was used to simulate the metabolism for the steroid moiety of cholic acid with excellent agreement between simulated and experimental results. This simulation also had utility since it predicted that isotope dilution studies of bile acids would give erroneous results if the isotope was injected in the form of its taurine conjugate. The model was subsequently extended to predict the effects of perturbed bile acid metabolism in patients with diseases affecting the enterohepatic circulation of bile acids (17).

With the development of sensitive specific radioimmunoassays for individual bile acid classes (18–21), it became possible to detect the pulsatile rhythm of the enterohepatic circulation of bile acids (22–25). The acceleration of the enterohepatic flow during digestion was signaled by a striking increase in the serum level of bile acids. With this information and other experimental evidence indicating that the fractional hepatic extraction of any given bile acid species remained relatively constant throughout the day (26–29), it became possible to construct steady-state multicompartmental models (30, 31) that encompassed most aspects of bile acid metabolism in man. However, since no time-dependent parameters were included in the model, the model could not be used to simulate the dynamics of the enterohepatic circulation of bile acids in man.

This paper contains the description of a complete dynamic multicompartmental model for bile acids in man. It also reports the application of this model to simulate the metabolism and enterohepatic circulation in health of cholic acid and its conjugates, as well as a comparison of the simulated data with published experimental data. The paper represents the results of a collaboration between an American program of clinical investigation (32) and an Italian program of mod-

eling and simulation of physiological processes (33, 34). In future studies, we hope to apply the model to the other major primary and secondary bile acids and also to describe and simulate the disturbances in bile acid metabolism that may occur in liver and intestinal disease.

## METHODS

### Description of the model

#### GENERAL DESCRIPTION

**General principles.** The present model, as any multicompartmental model (35), consists of well mixed compartments that contain identifiable chemical species and whose unit is mass, specifically micromoles. The model does not deal with concentrations, but if the volume of distribution of any chemical species is known, its concentration is easily calculated. Movements of molecules between compartments are termed fluxes; movements into a pool are termed influxes, and movements out of a pool are termed effluxes. Movements are denoted by transfer coefficients whose unit is reciprocal time, specifically minutes<sup>-1</sup>. The flux is the product of the mass in question times its particular transfer coefficient and has the units of micromoles/minute. The model, as described here, is a linear model, i.e. transfer coefficients are constant and uninfluenced by the mass in the compartment. The model can be modified, if desired, to exhibit saturation kinetics.

The model is made time dependent by using one value

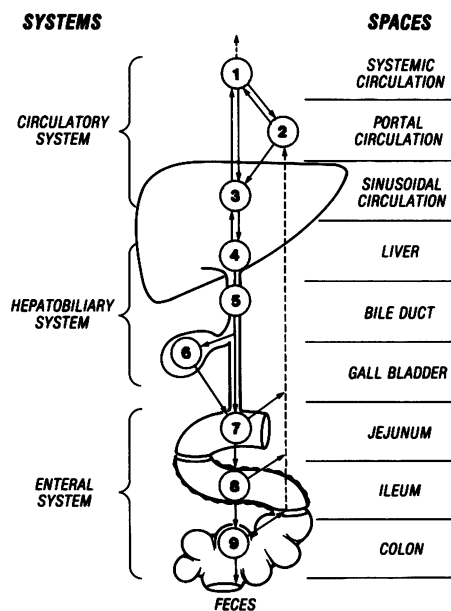

FIGURE 1 Anatomic depiction of systems and spaces in the model. Justification for the aggregation of the circulatory system into three spaces is given in the text. The diagonal arrows from the enteral spaces denote absorption into the portal circulation.

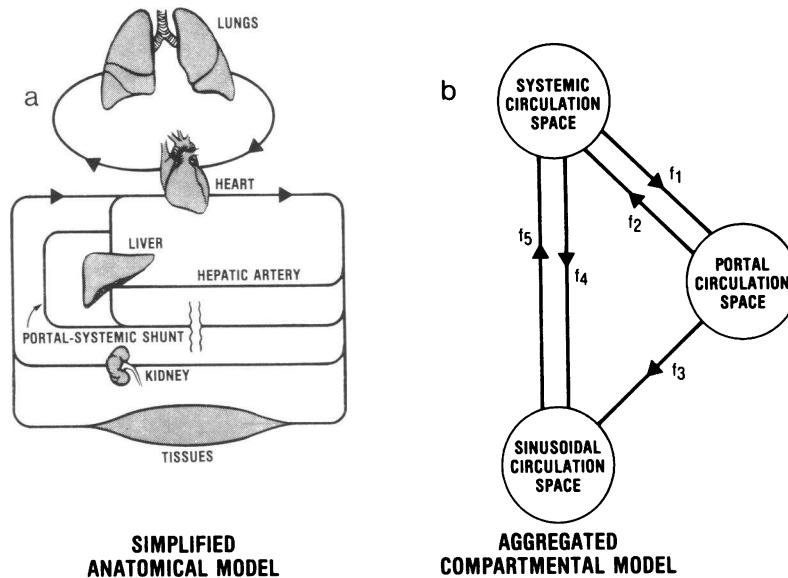

FIGURE 2 a, conventional scheme of the circulation. b, compartmental model of circulation. The arrow from the systemic circulation to the portal space ( $f_1$ ) indicates the mesenteric blood flow; that for the systemic circulation to the sinusoidal space ( $f_4$ ) indicates the hepatic arterial blood flow. The arrow from the sinusoidal space to the systemic circulation ( $f_5$ ) indicates hepatic venous blood; that from the portal space to the systemic circulation ( $f_2$ ) denotes portal systemic shunting.

for the transfer coefficient in the fasting state and a second value for the transfer coefficient in the "digestive" state. Our model is at steady state in that the masses in the model have periodic variation throughout the day, but after 24 h return to the same value; input into the model from *de novo* synthesis is balanced by simultaneous loss. The model describes events for a period of 1,440 min (1 d) and thus can be continued for an indefinite number of days.

**Definition of compartments.** The broad features of the model are illustrated in Fig. 1. The model consists of three systems, defined on the basis of function: the hepatobiliary system, the enteral system, and the circulatory system.

Each system consists of three spaces, defined on the basis of anatomy. Thus, since there are three systems each containing three spaces, there are nine spaces in all, denoted by the numbers 1-9.

The hepatobiliary system consists of a liver space, a gallbladder space, and a bile duct space. The latter two spaces will be called the biliary system.

The enteral system consists of a jejunal space, an ileal space, and a colonic space. As is discussed below, for symmetry, each space should be divided into two subspaces: a luminal space and a cellular space. In the present model, these spaces are "lumped."

The circulatory system consists of a portal space, a sinusoidal space, and a systemic circulation space. For the purpose of this space, we judged that some possible spaces were unnecessary; these have also been lumped. By using conventional procedures for compartmental modeling, it is possible to derive from a conventional scheme of the circulation shown in Fig. 2a the three-compartment model of Fig. 2b, which shows the spaces of interest: (a) portal space, (b) sinusoidal space, and (c) systemic circulation space that corresponds to the aggregation of lung, heart, kidney, and tissues of Fig. 2 (Belforte et al. Manuscript in preparation.).

Each space consists of three compartments defined on a chemical basis, i.e. cholic acid (chl);<sup>1</sup> its glycine conjugate, cholyglycine (chl-gly); and its taurine conjugate, cholytaurine (chl-tau). Homologous compartments are denoted by decimals, e.g. 4.1, 4.2, and 4.3, as shown in Fig. 3. Obviously, the total mass in a space is the sum of the mass in the individual compartments, and the total influx to or efflux from any space is the sum of the individual fluxes of its constituent compartments.

**Definitions of transfer coefficients.** Transfer coefficients are organized in this model by physiological mechanisms.

Flow coefficients (denoted by  $f$ ) denote transfer coefficients describing movements resulting from external forces acting on an entire space and that result in the movement of all of its compartments at the same rate.

For the hepatobiliary system, the flow coefficients denote the bile acid flux attributable to flow of bile from the bile duct into the gallbladder, flow of bile from the bile duct into the jejunum, and gallbladder emptying into the jejunum.

For the enteral system, flow coefficients describe transfer of mass from the jejunal space into the ileal space, transfer of mass from the ileal space to the colonic space, and transfer of mass from the colonic space to the outside.

In the circulatory system, flow coefficients describe movement of substances caused by blood flow from the portal space to the sinusoidal space, from the sinusoidal space to the systemic circulation and from the systemic circulation to the sinusoidal and portal space.

The parameters for this circulatory model apply to any substance circulating in blood since they are very simple

<sup>1</sup> Abbreviations used in this paper: chl, cholic acid; chl-gly, cholyglycine; chl-tau, cholytaurine; MEHCCA, metabolism and enterohepatic circulation of cholic acid.

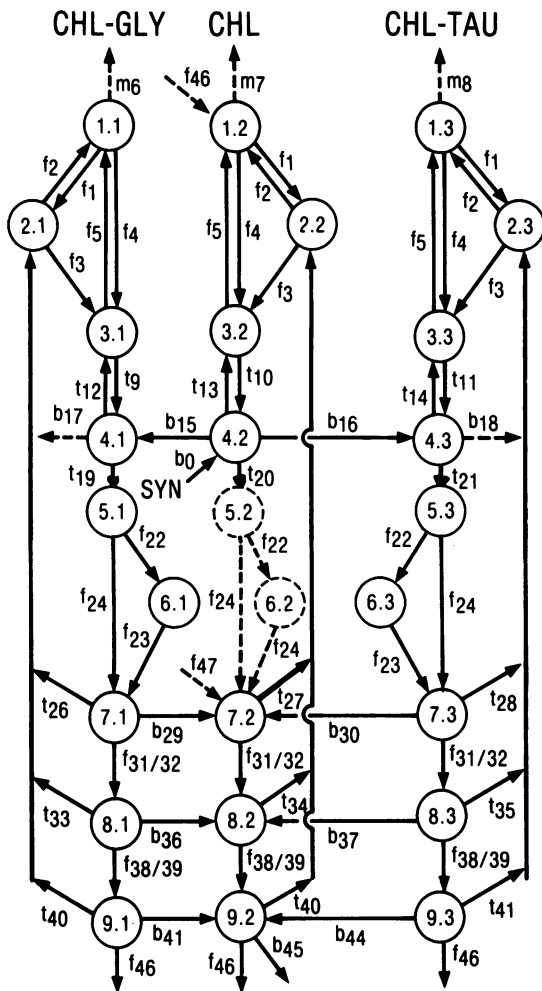

FIGURE 3 Compartments and transfer coefficients of the model. Transfer coefficients denoted by  $f$  refer to flow; by  $t$ , to transport; and by  $b$ , to biotransformation. For details, see text. The dotted lines denote a flux considered not to occur in health, i.e., biliary secretion of cholic acid (chl) in the unconjugated form ( $t_{20}$ ) or oral ingestion of bile acids ( $f_{47}$ ).

fractions of the different flows and volumes of the circulatory system (Belforte et al., Manuscript in preparation). For example, the transfer coefficient (transfer flow from systemic to sinusoidal compartment) is:  $f_4$  = Hepatic artery flow/Volume of general blood.

Biotransformation coefficients (denoted by  $b$ ) denote transfer coefficients describing fluxes from one compartment to another compartment caused by formation, alteration, or lysis of a covalent bond. In this particular model, the biotransformation coefficients involve only conjugation or deconjugation. Also, in this particular model, all biotransformation coefficients occur in only the liver space or one of the three enteral spaces.

Transport coefficients (denoted by  $t$ ) denote transfer coefficients describing fluxes from one space to another space that involves passage across cell membranes. Physiologically, such fluxes involve active or passive transport or both. Thus,

in this model, the flux is the product of the transport coefficient times the mass of its donor compartment.

Mixed coefficients (denoted by  $m$ ) denote transfer coefficients that represent both flow and transport. In this model, they refer to renal excretion. However, since renal excretion of cholic acid and its conjugates is essentially nonexistent in health (36), such coefficients and corresponding fluxes will be discussed only to a very limited extent.

*Time dependent assumptions. General principles.* The enterohepatic circulation of bile acids has a diurnal rhythm that is determined by eating. When a meal is eaten, there is a three- to sixfold increase in secretion of bile acids (37, 38) which is then reflected by a three- to sixfold postprandial increase in serum bile acid levels (22-25). Two additional lines of evidence show that this effect is caused by the eating of a meal. First, serum bile acid levels remain low and relatively constant during fasting, suggesting that bile acid secretion is greatly reduced when meals are not ingested; nonetheless, there is some enterohepatic cycling of bile acids, since bile acids are always present in serum. It is known that intestinal transit continues during the fasting state because of the interdigestive motility complex (39). Second, bile acid secretion remains constant and at a high level during infusion of a liquid meal (40). Thus, any complete description of the enterohepatic circulation of bile acids should include an increase in the flux of bile acids during digestion and a decrease in the bile acid flux during the fasting state.

Intestinal motility is the major factor responsible for rhythm of the enterohepatic circulation, since bile acids must move during digestion from the duodenum to the terminal ileum where they are actively absorbed. Flow in the intestine is known to increase during digestion (41). Gallbladder contraction, on the other hand, is only partially responsible for the rhythm of the enterohepatic circulation since rhythmic secretion into the intestine and spillover into the general circulation is changed little by cholecystectomy (25). Nonetheless, gallbladder contraction and storage must determine to some extent the amount of bile acids circulating in the enterohepatic circulation (cf. 42); therefore, flow coefficients for gallbladder filling and emptying must be included in the dynamic model.

Since these time-dependent transfer coefficients are flow coefficients, they apply to all compounds in a given space and may be considered general assumptions, as they will apply to any compounds whose metabolism is similar to that of bile acids.

#### DETAILED DESCRIPTION OF THE MODEL

*General principles and assumptions.* In the following discussion, general assumptions are defined as those that could apply to any molecules whose metabolism and enterohepatic circulation is qualitatively similar to that of bile acids. These assumptions will usually involve fluxes determined by flow coefficients, which describe fluxes between spaces caused by blood circulation (circulatory system) or emptying (biliary system or enteral system). Specific assumptions refer to aspects of the model that apply to bile acids as a class of compounds. These are bile acid specific because they depend on molecular structure. They refer to transport coefficients between spaces and biotransformation coefficients within spaces.

*Hepatobiliary system.* The model assumes that the hepatocyte can be treated as a single space termed the liver space.

The influx into the liver space is the sum of the fluxes resulting from *de novo* synthesis and uptake from the si-

nusoidal space. Synthesis is assumed to be a constant flux, i.e., the small diurnal variation in bile acid synthesis is neglected (43, 44). Uptake from the sinusoidal space is related to molecular structure and is therefore described by a transport coefficient times the mass in the homologous donor compartment.<sup>2</sup>

Efflux from the liver space is primarily into the biliary system, i.e., the bile duct space. The efflux is assumed to be influenced by molecular structure in the liver space and is therefore described by a transport coefficient times the mass of the respective donor compartment. Reflux from the hepatic space back to the sinusoidal space is also included in the model; since this is dependent on molecular structure, it is described by a transport coefficient.

**BILE DUCT SPACE.** The model assumes that the entire biliary system (hepatic ductules, hepatic ducts, and common hepatic duct) may be described adequately by a single space. This assumption is certainly an oversimplification, but the lumping of the biliary compartments did not cause difficulty in the present model.

The influx into the bile duct space is the flux from the liver. The efflux from the bile duct space is discharge into the jejunum or diversion into the gallbladder.

**GALLBLADDER SPACE.** The gallbladder is also described by a single space. The influx is from the bile duct space.

The efflux represents gallbladder emptying into the jejunum through the bile duct space. Emptying has been assumed to be exponential in the simulation. When gallbladder influx exceeds efflux over some time interval, filling occurs; and this may be defined as gallbladder storage (cf. 38). The model assumes that there is no absorption of bile acids from the bile duct or gallbladder spaces. This assumption may not be true, but the magnitude of such an absorptive flux, at least in health, is probably negligible.

**Enteral system.** The model assumes that the entire intestine can be described by three spaces: a jejunal space, an ileal space, and a colonic space. Obviously, the model could be refined by subdividing each enteral space into two or more subspaces (cf. 46). In this paper, as noted above, we have not distinguished an intraluminal subspace from a cellular subspace, since the mass of bile acids in the enterocyte has never been measured in man and is considered to have no pathophysiological significance.

**JEJUNAL SPACE.** A jejunal space is necessary because bile acid absorption from the jejunum is only passive and the transport coefficients differ substantially for individual bile acids (2). In addition, because bile acids have important functional effects in the jejunum in mediating lipid absorption and since this function is concentration dependent, it is desirable to have a jejunal space, if the model is to be used to predict the effect of perturbations of bile acid metabolism on lipid absorption. It is also helpful to have a jejunal space since it may be desirable to apply the model to patients with ileal dysfunction or resection.

The influx into the jejunal space is the sum of the fluxes from the bile duct and the gallbladder spaces. Because gallbladder emptying has been made time dependent, this influx into the jejunal space will be time dependent.

There are three potential effluxes from the jejunal space

and indeed from all of the enteral spaces. The first efflux is absorption into the portal blood space, which is described by a transport coefficient, since it is dependent on molecular structure. The second efflux is biotransformation to other bile acids, mediated by enteral bacteria; this is described by a biotransformation coefficient. The third efflux is to the next enteral space, i.e. transfer of mass to the ileal space. This is described by a flow coefficient.

**ILEAL SPACE.** An ileal space is necessary since active absorption of bile acids occurs in the ileum, and since the ileum may be resected in patients. Anatomically, the jejunum precedes the ileum, and such is also true in the model. Flow from the jejunum to the ileum is unidirectional in man and in the model. The time course of serum bile acid levels in man after a meal reflects sequential absorption in the jejunum and ileum (29).

The influx into the ileal space is the flux from the jejunal space, termed jejunal emptying. The three types of effluxes from the ileal space correspond to those already discussed from the jejunal space.

**COLONIC SPACE.** A colonic space is necessary since biotransformations occur in the colon that do not occur in the jejunum or ileum, for example 7-dehydroxylation. Further, the absorptive characteristics of the colonic mucosa differ from those of the jejunum and ileum, and colonic absorption of bile acids occurs.

The influx into the colonic space is the flux caused by ileal emptying. The types of efflux are identical to those of the jejunum and ileum: absorption, described by a transport coefficient; emptying to the outside, described by a flow coefficient; and biotransformations, described by biotransformation coefficients. It might be commented that bile acids present in solid feces are considered to be outside, i.e., to have left all of the spaces of the model.

**Circulatory system.** Three circulatory spaces are described by flow coefficients.

**PORTAL BLOOD SPACE.** A portal space is required, for the reason that in liver disease there may be portal-systemic shunting, in which instance the flux entering the portal space will be greater than that entering the sinusoidal space. The portal space must be distinguished from the sinusoidal space, as it has a different bile acid concentration, since sinusoidal blood flow derives from both arterial and portal blood flow.

The major influx into the portal space is the sum of the individual fluxes from the jejunal, ileal, and colonic spaces. Because the flux from each compartment is dependent on molecular structure, the total flux will be the sum of the products of as many as nine transport coefficients times the mass in as many as nine donor compartments. The minor flux into the portal compartment is the product of a flow coefficient times the mass in the systemic circulation space.

The efflux from the portal space is described by a flow coefficient to the sinusoidal space. This is the only efflux in health; in liver disease, there may be portal-systemic shunting described by a flow coefficient from the portal space to the general circulation space.

**SINUSOIDAL SPACE.** A sinusoidal space is required since hepatic uptake occurs exclusively from it and since it has a different bile acid concentration from that of the systemic circulation space of the portal blood space. Such a space is useful for defining "first-pass clearance."

The influx into the sinusoidal space is from portal blood space, from the systemic circulation space, and from the liver space. The largest influx is from the portal space and is described by a flow coefficient. The influx from the systemic circulation represents mass carried in hepatic artery blood flow; this flux is also described by a flow coefficient.

<sup>2</sup> The model assumes that uptake can be described by a lumped compartment, even though elaborate distributed models for hepatic uptake of bile acids and other hepatophilic anions have been described (45). The justification for describing hepatic uptake by a single lumped compartment has been fully discussed elsewhere (34).

The influx from the liver space describes mass that "refluxes" from the liver space into the sinusoidal space. As stated previously, this reflux is presumably dependent on bile acid structure, and will be described by a transport coefficient.

The effluxes from the sinusoidal space are described by a flow coefficient representing blood flow from the sinusoidal space to the systemic circulation and a transport coefficient reflecting hepatic uptake.

**SYSTEMIC CIRCULATION SPACE.** A systemic circulation space is required since this space has a different bile acid concentration than the portal space or the sinusoidal space, as noted. The influx to the systemic circulation space is "spill-over" from the sinusoid, as has been discussed.

The efflux from the systemic circulation space is mass transferred via the mesenteric blood to the portal space, i.e., via the celiac artery, and mass transferred to the sinusoidal space by the hepatic artery. Both of these fluxes involve flow coefficients. There is a potential efflux in urine, whose rate is negligible in health and is denoted here by mixed transfer coefficients. Presumably, transfer coefficients for renal excretion would involve both flow coefficients (renal blood flow) and urine water flow transport coefficients, since both the glomerular filtration and tubular reabsorption should be structure dependent.

The number of compartments in the systemic circulation space is determined by the number of compartments in the hepatobiliary and enteral systems; this in turn is determined by the number of biotransformations.

**Assumptions for time-dependent features.** As discussed above, the stimulus for acceleration of the enterohepatic circulation is eating. In the model, meals were eaten at 0700 (420 min), at 1300 (780 min), and at 1900 h (1,140 min).

#### *Hepatobiliary system.*

**LIVER SPACE.** No change in the transfer coefficients determining influx or efflux into the liver space were made during eating.

**BILE DUCT SPACE.** The flow coefficient describing bile duct emptying was kept constant. Bile acids are choleric, so that increased bile flow might increase the transit rate through the bile duct space; this effect was not considered in the original simulation. The effect of increasing the emptying rate during eating would be negligible.

**GALLBLADDER SPACE.** Gallbladder contraction begins as soon as the meal is ingested and is exponential, with a rate constant of  $0.04 \text{ min}^{-1}$  (47). This corresponds to a  $t_{1/2}$  of  $\approx 17$  min and a 95% emptying time of 75 min. The time period in which gallbladder emptying was allowed was 90 min after each meal. The gallbladder was then allowed to fill passively without a limit on its content. The absence of a filling limit was chosen for modeling convenience; however, the healthy gallbladder concentrates bile by water absorption, so that there need be no direct relationship between gallbladder volume, which might well have anatomical limits, and bile acid content, which could continue to increase without a change in gallbladder volume as bile was concentrated. The model does not include a sphincter of Oddi, so that flow from the bile duct into the jejunal space never stops. Continuous secretion of bile in the fasting state appears to occur in healthy subjects (38).

#### *Enteral system.*

**INTESTINAL MOTILITY.** Intestinal motility refers to the emptying of each enteral space into its contiguous enteral space. Intestinal motility is continuous throughout the day, but is modified during digestion: the net effect was assumed to reduce the transit time by a factor of  $\sim 0.8$ . The digestive period was restricted to 2 h (41).

**CIRCULATORY SYSTEM.** No changes were made in the flow

coefficients determining fluxes between the spaces of the circulatory system. Portal blood flow is known to increase during digestion but the effect of this increased portal blood flow per se on hepatic fractional extraction of bile acids is small (26–28).

### APPLICATION OF THE MODEL TO CHOLIC ACID

Having stated the general and certain bile acid specific assumptions of the model, we can now apply it in detail to cholic acid. The major new considerations are the fluxes to and from individual compartments that will be transport and biotransformation coefficients. All spaces contain three compartments: unconjugated cholic acid, chl-gly, and chl-tau.

#### *Hepatobiliary system.*

**THE CHOLIC COMPARTMENT.** The influx to the cholic compartment is constant *de novo* synthesis from cholesterol (represented by the oblique arrow entering from below) and the flux from the sinusoid.

The efflux from the cholic compartment is by biotransformation to chl-gly and chl-tau. The rate of glycine conjugation is several times that of taurine conjugation (48, 49). The model also indicates a potential flux of unconjugated cholic acid into the bile ducts and gallbladder.<sup>3</sup>

The chl-gly compartment has an influx from its donor sinusoidal compartment. The transfer coefficient is the transport coefficient reflecting the active uptake of chl-gly by the hepatocyte.

There are two effluxes from the chl-gly compartment: one of the bile duct compartment and "reflux" into the sinusoid. As noted above, these effluxes have been described by transport coefficients. Also shown in the figure is an efflux ( $b_{17}$ ) representing biotransformation by additional conjugation, such as sulfation. For cholic acid, in health, this efflux will be considered negligible, as sulfated species of cholic acid are not present in bile in healthy individuals (51, 52).

The chl-tau compartment has a similar influx from its donor sinusoidal compartment. We have used an identical value for the transport coefficient of chl-gly and chl-tau; the first pass extraction fraction of chl-gly has been determined for man (53), but not chl-tau. The plasma disappearance curves of chl-tau and chl-gly are quite similar in man (54).

The efflux from the chl-tau compartment is similar to that from the chl-gly compartment.

**BILE DUCT AND GALLBLADDER COMPARTMENTS.** Since there is neither absorption nor biotransformation in these compartments, the influxes and effluxes have already been discussed fully under general assumptions.

#### *Enteral system.*

**JEJUNAL SPACE.** The chl-gly compartment has its influx from the homologous bile duct compartment, which is described by a flow coefficient. There are three effluxes. The first efflux is intestinal absorption, which involves a transport coefficient. The second efflux is deconjugation by intestinal bacteria, which involves a biotransformation coefficient. The third efflux is by emptying, which involves a flow coefficient. Exactly the same principles apply to the chl-tau compartment.

For the cholic acid compartment, however, there are three

<sup>3</sup> Although the magnitude of this flux is probably negligible in health, it seems desirable to include unconjugated cholic acid compartments in the bile duct and gallbladder spaces since unconjugated bile acids are present in serum (50) and quite possibly in bile of patients with liver disease.

influxes. The first results from secretion of unconjugated cholic acid into the jejunum via its homologous bile duct compartment; this influx, which is negligible in health, is described by a flow coefficient. The second and third influxes result from deconjugation of chl-gly and chl-tau; they are described by the respective biotransformation coefficients. There are two effluxes from the cholic acid compartment. Intestinal absorption is described by a transport coefficient. In addition, there is jejunal emptying of the cholic acid compartment to the homologous cholic acid compartment in the ileal space.

**ILEAL SPACE.** The ileal space also has three compartments whose influxes and effluxes are described by similar principles. The influx, however, is solely from jejunal emptying, rather than from the biliary system. The efflux pathways are completely analogous to those described for the jejunal space.

**COLONIC SPACE.** The colonic space also has three compartments. Again, the influx is solely from ileal emptying. The effluxes from the colonic space have some characteristics that distinguish them from those of the ileal space. An additional biotransformation, 7-dehydroxylation to deoxycholic acid, occurs in the colon. This dehydroxylation may occur for chl-gly (14) and chl-tau (55) so that these compartments have four possible effluxes: absorption, deconjugation, dehydroxylation, and loss to the outside.

For the cholic acid compartment, there are three possible effluxes. The conjugated or unconjugated deoxycholic acid that is formed is excreted to the outside or is absorbed. If absorbed, it undergoes a complete metabolism and enterohepatic circulation exactly analogous to that described here for cholic acid (12). The loss of cholic acid, i.e. the sum of immediate loss to the outside as well as that which recycles as deoxycholic acid and is subsequently lost, is equal to the hepatic synthesis of cholic acid.

**Circulatory system.** There are no specific assumptions for cholic acid; the general assumptions have been discussed.

## Simulation of metabolism and enterohepatic circulation of cholic acid (MEHCCA) in health

### SELECTION OF VALUES FOR SIMULATION

**Generalities.** For the simulation, we first selected the "best" or average values from the literature for the volumes of the spaces, the concentration of individual species in the spaces, and the fluxes between spaces.

Most literature values are given in concentrations and fluxes, rather than in masses (of compartments or spaces) and transfer coefficients. However, if the volume of distribution of a given space or compartment is known, its mass is easily calculated. Similarly, if the flux has been measured or can be estimated and if the mass in donor space or compartment is known, the transfer coefficient may be estimated. Table I summarizes published values for the volumes of the spaces in the model and denotes the values assumed for the simulation.

**Overall balance.** In our model, the total mass, which is the exchangeable pool for all cholic acid species obtained with the simulation, was  $\sim 1,600 \mu\text{mol}$  (0.66 g). The synthesis has been taken as  $0.44 \mu\text{mol}/\text{min}$  or  $634 \mu\text{mol}$  (260 mg)/d. Fecal output is zero, as all cholic acid is considered to be dehydroxylated to deoxycholic acid, whose daily rate of formation must be equal to the daily rate of cholic acid synthesis. These two values give a daily fractional turnover rate of  $0.000028 \text{ min}^{-1}$  ( $0.40 \text{ d}^{-1}$ ), which agrees with literature values (9, 10).

**Hepatobiliary system.** The total concentration of cholyl spaces in the liver space, i.e., the sum of the masses in the chl-gly, chl-tau, and chl compartments divided by the volume of distribution has been reported by Greim et al. (56), who found a total concentration of  $\sim 40 \text{ nmol}/\text{ml}$  hepatic water in liver biopsy samples obtained from healthy patients.

TABLE I  
Volumes of Spaces (ml): Published and Assumed Values

Compartments	Volume, ml			References	
	Published average mean value	Assumed range	Assumed values		
<b>Hepatobiliary system</b>					
Hepatic space	4.1, 4.2, 4.3	900	800–1,000	950	82, 83
Bile duct space	5.1, 5.2, 5.3	45	40–50	20	82, 83
Gallbladder space	6.1, 6.2, 6.3	30	20–40	20	47, 82, 83
<b>Enteral system</b>					
Jejunal space	7.1, 7.2, 7.3	200	200–500*	300	60
Ileal space	8.1, 8.2, 8.3	100	100–500*	150	60
Colonic space	9.1, 9.2, 9.3	300	300–1,000*	450	84, 85
<b>Circulatory system (plasma)</b>					
Systemic space	1.1, 1.2, 1.3	2,500	2,000–3,000	2,460	86
Portal space	2.1, 2.2, 2.3	450	400–500	420	86
Sinusoidal space	3.1, 3.2, 3.3	200	100–300	120	86, 87

\* The values given are considered to be within the physiological range during the fasting state condition.



**CHL COMPARTMENT.** The influx into the chl compartment is the cholic acid synthesis from cholesterol plus the cholic acid absorbed from the intestine and transferred from the chl portal compartment. This flux derives from the deconjugation in the ileal space of chl-gly and chl-tau and the subsequent absorption of chl, whose rate is defined by its transport coefficient. Estimates of the magnitudes of influx of chl from the enteral system are derived below. We can estimate that the chl compartment of the liver space receives ~600 nmol/min from intestinal biotransformation and 440 nmol/min from *de novo* synthesis (16). Thus the majority of the influx into the chl compartment is from unconjugated cholic acid formed in the distal small intestine by bacterial deconjugation of previously secreted conjugates of cholic acid.

The efflux from the chl compartment is by biotransformation to chl-gly or chl-tau. In the simulation, we shall assume that conjugation is complete and that the rate of conjugation with glycine is three times that of conjugation with taurine.<sup>4</sup>

A second efflux from the hepatic space is "reflux" as unconjugated cholic into the sinusoidal space. The available estimates of this flux (57-59) suggest that its magnitude is quite small. A third possible efflux is transport of the chl without biotransformation into the biliary duct compartment. This is presumed not to occur in healthy man and is shown in Fig. 4 as a dotted line.

**CHL-GLY COMPARTMENT.** The major input into the chl-gly compartment is returned from the intestine, i.e., chl-gly, which is absorbed without deconjugation. The minor input is from newly conjugated chl-gly entering from the chl compartment. (See also Table VII).

The major efflux is transport into the bile duct compartment. The minor efflux is reflux back into the sinusoidal compartment, which is described by a transport coefficient and for which a few estimates are available from the literature (57-59).

**CHL-TAU COMPARTMENT.** For chl-tau, the influx assumptions are similar. Less chl-tau is deconjugated in the intestine, so that it mainly is absorbed intact. Similarly, the input of chl-tau from the chl compartment by conjugation with taurine is also less.

For reflux from the hepatic space into the sinusoidal space, we have used an identical transport coefficient for chl-tau as for chl-gly.

**Biliary system.** Transfer through the bile duct and gallbladder spaces already has been summarized.

Obviously, secretion of bile acids into the intestine depends on flow from the bile duct space and the gallbladder space.

**Enteral system.**

**JEJUNAL SPACE.** In our model, it is assumed that there is no passive absorption of chl-gly or chl-tau so that the transport coefficient is zero. Similarly, there is no deconjugation so that the biotransformation coefficient is zero. Thus, the mass of the chl compartment is zero.

The only efflux from the jejunal space is into the ileal space. Only one parameter, a flow parameter, is necessary

<sup>4</sup> Although the ratio of glycine to taurine conjugated bile acids in bile is about three, the relative rates of hepatic conjugation with glycine or taurine may not be identical to the steady-state proportions in bile, since the latter is determined not only by the relative rates of hepatic conjugation, but also by the relative rates of intestinal conservation of the two classes of conjugates (17).

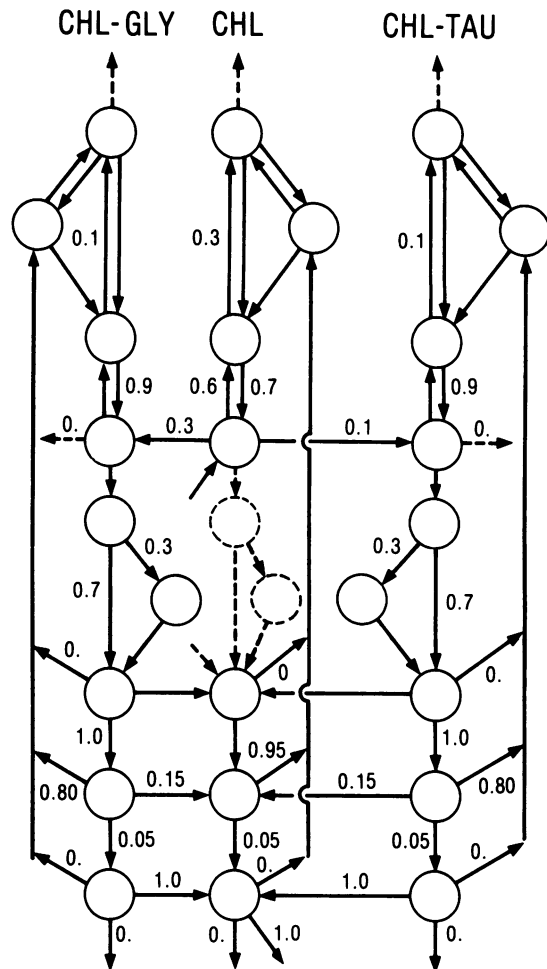

FIGURE 4 Relative values, based on values in the literature, for effluxes from individual compartments in fasting state condition. These values were used to derive the values for the transfer coefficients used for the simulation (see Table III).

for the model, since it is a mechanical flow that applies to all jejunal compartments. During digestion, the parameter has been increased 1.2-fold to account for increased intestinal motility (41, 60).

**ILEAL SPACE.** The influx into the chl-gly compartment is the emptying of the jejunal donor compartment. The efflux is by absorption, emptying into the colon, or deconjugation. The absorption rate, described by transport coefficients, is very efficient, reflecting the summation of active and passive transport from the ileal space. About 15% of the secreted amount of chl-gly and chl-tau is deconjugated in the ileum so that one-sixth of the secreted amount of cholyl conjugates enter the chl compartment. The chl compartment receives influx from deconjugation of chl-gly and chl-tau, the influx from the chl-gly compartment being greater than from the chl-tau compartment.<sup>5</sup>

<sup>5</sup> Fluxes of cholyl species into and out of the ileal space may be exemplified as follows. The fasting state secretion

**COLONIC SPACE.** Input into the chl-gly compartment is chl-gly not absorbed in the ileum, and described by the flow coefficient of ileal emptying.

In this model, we have assumed that chl-gly is fully deconjugated to chl. There is no absorption of chl-gly as such from the colonic space. The chl-tau compartment has a similar influx and efflux.<sup>6</sup>

The chl compartment receives influx from the donor chl-gly and chl-tau compartments, as well as a small influx from that fraction of the ileal chl compartment that was not absorbed. In the model we have assumed that the chl in the colonic compartment is fully 7-dehydroxylated to form deoxycholic acid, i.e., that there is no absorption of unconjugated cholic acid from the colonic space. This is probably not true, but colonic permeability for cholates is low (62). A fraction of the deoxycholic acid that is formed is absorbed and undergoes enterohepatic cycling in a manner identical in principle to that discussed above for cholic acid (63), but consideration of the metabolism of deoxycholic acid is beyond the scope of this paper.

#### *Circulatory system.*

**PORTAL SPACE.** All assumptions have been discussed previously.

**SINUSOIDAL SPACE.** The influx to the sinusoidal space is portal blood flow plus the small amount of flux by the hepatic arterial blood flow. The efflux is the uptake by the liver space, which is described by the transport coefficient. As an example, for chl-gly, the first-pass extraction fraction is  $t_9/(f_5 + f_9)$ . Spillover is 1 minus the first-pass extraction fraction.

For chl-gly, the first-pass clearance has been taken as 0.9 (28, 53); a similar value has been taken for chl-tau. For chl, the first-pass clearance is less, and the value of 0.7 has been used (64).

**SYSTEMIC CIRCULATION.** The influx into the systemic circulation compartments is spillover from the sinusoidal compartments. The efflux is due to hepatic arterial blood flow and mesenteric artery blood flow; they are described by flow coefficients, as noted. The relative mass in individual sys-

---

of bile acids is  $\sim 10 \mu\text{mol}/\text{min}$  (36, 39). Since cholic acid composes  $\sim 35\%$  of biliary bile acids, this corresponds to  $3\text{--}4 \mu\text{mol}/\text{min}$  (3 of chl-gly and 1 chl-tau, respectively). It is assumed that  $\sim 15\%$  of the secreted amount of chl-gly and chl-tau is deconjugated and that the chl-gly and chl-tau that are not deconjugated are mostly absorbed. Thus, of the  $3 \mu\text{mol}/\text{min}$  of chl-gly secreted,  $\sim 2.5 \mu\text{mol}/\text{min}$  are reabsorbed,  $0.4 \mu\text{mol}/\text{min}$  of the chl enter the ileal chl compartment, and  $0.4 \mu\text{mol}/\text{min}$  is not absorbed and flows into the chl-gly colonic compartment. Of the  $1.0 \mu\text{mol}/\text{min}$  of chl-tau secreted,  $0.8 \mu\text{mol}/\text{min}$  is reabsorbed,  $0.16 \mu\text{mol}/\text{min}$  of chl formed by deconjugation enters the ileal chl compartment, and  $0.04$  is not absorbed and flows into the chl-tau colonic compartment.

<sup>6</sup> It is recognized that the assumptions that chl-gly and chl-tau are fully deconjugated and not absorbed are arbitrary; but fecal bile acid analyses show that bile acids are fully deconjugated (61), and assignment of different values would influence calculated fluxes to a very small extent as the mass of bile acids in the colonic space is quite small. As noted, there is experimental evidence that chl-gly and chl-tau are not fully deconjugated before dehydroxylation (14, 55). We have not indicated this by biotransformation coefficients from compartments 9.1 and 9.3, as the model is for cholic species only.

temic circulation compartments is determined by the relative transport coefficients for influx into the hepatic space from the sinusoidal space, since the spillover is the complement. Thus, the model predicts that the cholyl species in the systemic circulation space should always be enriched in chl relative to the portal species in portal blood. As yet there is no experimental evidence for this prediction, but evidence that the systemic circulation always contains chl in appreciable concentrations has recently been published (50).

The rhythm and the levels of the three compartments in the general circulation is determined by intestinal motility and gallbladder emptying.

## MATHEMATICAL METHODS

*Modeling methodology.* The major problem, from the modeling point of view, is related to the great complexity of MEHCCA. The physiological requirement for a sufficiently detailed model to encompass the major aspects of cholic acid metabolism contrasts markedly with the limited amount of experimental information available. The usual approach in such a situation is to use a highly aggregated model, as for a specific example, the single pool model of Lindstedt (8). However, the use of highly aggregated models has several drawbacks, particularly in cases of cognitive models, as the present one. Indeed, the use of highly aggregated models can even lead to incorrect interpretation of experimental data (33, 34, 65).

To solve these problems, we have used a new method that is termed a parameter aggregation method (66, 67). The key problem in constructing a model of a real process is that of obtaining not only satisfactory interpretation of available experimental data but also "good" predictions of new data that have not been used for the construction of the model. Recent research has shown that these requirements imply a suitable balance between the model "complexity" and the information available in the experimental data. Roughly speaking, as the model complexity increases (i.e. as the number of compartments is increased or nonlinear transfer coefficients are used), the fitting of the experimental data improves, but the predictive ability of the model worsens for a given amount of information (68).

It has also been shown that in many situations, the number of unknown parameters of a model is a satisfactory index of its complexity (68). From this point of view, the use of highly aggregated models is interpreted as a method for solving the problem of complexity by reducing the number of compartments, aggregating groups of them. In this way, a reduction of the number of the transfer rates is also obtained.

However, the physiological correspondence between the process and the model is in general weakened and the physiological interpretation of transfer rates and data related to the model may be sometimes misleading (33, 65). On the contrary, the parameter aggregation approach is a method for reducing the complexity of a model without sacrificing its physiological structure and interpretation. The complexity reduction is not obtained by reducing the number of transfer rates (as in the compartment aggregation approach), but only by reducing the number of unknown parameters in the model, imposing suitable constraints among them.

Although this method may appear quite arbitrary at first sight, it has been shown (65, 66) to be superior to the usual compartment aggregation approach. In particular, the latter can be obtained easily as a particular case of the former. This implies that the parameter aggregation method has a

TABLE II  
Bile Acid Concentrations in Individual Compartments: Published and Obtained Values

Compartments	Published	Presumed range	Obtained values	References	
	<i>nmol/ml, average mean value</i>	<i>nmol/ml</i>			
<b>Hepatobiliary system</b>					
<b>Hepatic space</b>					
Chl-gly	4.1	*	12-36	12	56
Chl-tau	4.3	*	4-12	4	56
Chl	4.2	*	14-16	11	56
<b>Bile duct space</b>					
Chl-gly	5.1	9,000	5,000-10,000	7,800	88
Chl-tau	5.3	3,000	2,000-5,000	2,700	88
Chl	5.2	0	0	0	
<b>Gallbladder space</b>					
Chl-gly	6.1	36,000	25,000-50,000	34,000	88, 89
Chl-tau	6.3	9,000	5,000-15,000	12,000	88, 89
Chl	6.2	0	0	0	†
<b>Enteral system</b>					
<b>Jejunal space</b>					
Chl-gly	7.1	1,800	1,000-3,000§	2,700	90, 91, 92
Chl-tau	7.3	600	400-1,200§	900	90, 91, 92
Chl	7.2	0	0§	0	†
<b>Ileal space</b>					
Chl-gly	8.1	600	120-240 <sup>ll</sup>	208	90, 91, 92
Chl-tau	8.3	200	40-60 <sup>ll</sup>	74	90, 91, 92
Chl	8.2	100	25-50 <sup>ll</sup>	27	90, 91, 92
<b>Colonic space</b>					
Chl-gly	9.1	*	0-0.2	0.06	93
Chl-tau	9.3	*	0-0.2	0.02	93
Chl	9.2	*	0.3-0.6	0.52	93
<b>Circulatory system</b>					
<b>Systemic space</b>					
Chl-gly	1.1	0.4	0.3-1	0.35	18, 20, 23, 24
Chl-tau	1.3	0.2	0.1-0.5	0.12	18, 20, 23, 24
Chl	1.2	0.3	0.1-0.6	0.23	50
<b>Portal space</b>					
Chl-gly	2.1	4	1-6	2.7	94
Chl-tau	2.3	1	0.3-1.5	0.97	94
Chl	2.2	*	0.5-1.5	0.83	94
<b>Sinusoidal space</b>					
Chl-gly	3.1	*	—	0.35	†
Chl-tau	3.3	*	—	0.12	†
Chl	3.2	*	—	0.23	†

Values for fasting conditions.

\* Not available. Presumed range, for fasting normal subjects at steady state. Obtained values, at steady state in fasting condition (0700).

† Assumption of the model.

§ Published data for concentration during digestion.

TABLE III  
Assumed Values for Transfer Coefficients\*

	Coefficients	Assumed value		Coefficients	Assumed value
		$\text{min}^{-1}$			$\text{min}^{-1}$
Flow coefficients			Enteral system		
Hepatobiliary system			Deconjugation, colonic		
Bile duct → gallbladder	$f_{22}$	0.045	chl-gly → chl	$b_{42}$	5.0
Gallbladder → jejunum	$f_{23}$	0.04	chl-tau → chl	$b_{43}$	5.0
Bile duct → jejunum	$f_{24}$	0.0105	Dehydroxylation, colonic		
Enteral system			chl → dex	$b_{44}$	1.0
Jejunum → ileum (fasting)	$f_{30}$	0.006	Transport coefficients		
Jejunum → ileum (digestion)	$f_{34}$	0.0072	Hepatobiliary system		
Ileum → colon (fasting)	$f_{37}$	0.005	Hepatic uptake: sinusoid → liver		
Ileum → colon (digestion)	$f_{38}$	0.006	chl-gly	$t_9$	63.5
Colon → out	$f_{45}$	0	chl-tau	$t_{11}$	63.5
Circulatory system			chl	$t_{10}$	52.5
Mesenteric	$f_1$	0.27	Reflux from liver: liver →		
Portal-systemic shunt	$f_2$	0	sinusoid		
Portal	$f_3$	1.57	chl-gly	$t_{12}$	0.1
Hepatic arterial	$f_4$	0.098	chl-tau	$t_{14}$	0.1
Hepatic venous	$f_5$	0.9474	chl	$t_{13}$	0.1
Biotransformation coefficients			Biliary secretion: liver → bile		
Hepatobiliary system			ducts		
Conjugation			chl-gly	$t_{19}$	0.2
chl → chl-gly	$b_{15}$	0.06	chl-tau	$t_{21}$	0.2
chl → chl-tau	$b_{16}$	0.02	chl	$t_{20}$	0
Enteral system			Enteral system		
Deconjugation, ileal			Ileal absorption: ileum → portal		
chl-gly → chl	$b_{35}$	0.01	chl-gly	$t_{33}$	0.05
chl-tau → chl	$b_{36}$	0.009	chl-tau	$t_{34}$	0.05
			chl	$t_{35}$	0.1

\* Coefficients whose values are assumed to be zero have been omitted from the table for conciseness. For justification of these assumptions, see text. These are: mixed coefficients:  $m_6, m_7, m_8$ ; transfer coefficients:  $t_{25}, t_{26}, t_{27}, t_{39}, t_{40}, t_{41}$ ; flow coefficients: none; and biotransformation coefficients:  $b_{17}, b_{18}, b_{28}, b_{29}$ .

much greater flexibility in using physiological principles and information.<sup>7</sup>

<sup>7</sup> For example, the aggregation of the amount of the three cholic acid compounds in each space (generating the 9 compartment model of Fig. 1) is exactly equivalent to imposing in our model that the various transfer rates are the same for the three compounds (for example,  $t_9 = t_{10} = t_{11}$ ). On the contrary, in our model we can impose the physiological knowledge that the flow coefficients are equal, but biotransformation and transport coefficients may be quite different (for example that ileal absorption rates of free and conjugated cholic acids have a ratio of about two and then  $t_{33}$

*Numerical simulation.* The proposed mathematical model results in a set of linear, time-varying differential equations. The main problems for their numerical simulation arises from their stiffness (related to the great difference between the minimum and maximum transfer rate values, whose ratio is of the order of  $10^{-5}$ ). Thus, the use of general techniques for nonlinear differential equations (Runge-Kutta or predic-

$= 2t_{32}$ ). In this way, our model has the same number of unknown parameters (and then roughly the same complexity) of the aggregated nine compartment model, but gives a better interpretation of physiological data, thus resulting in a "better" model.

TABLE IV  
Volume Flows: Published Data and Values Used in Final Stimulation

	Published	Presumed range	Derived values	References
	<i>ml/min, average mean value</i>	<i>ml/min</i>		
Hepatobiliary system				
Bile ducts → gallbladder	0.2	0.1–0.3	0.09	47
Gallbladder → bile ducts	0	0	0	
Bile ducts → jejunum	0.5	0.2–0.6	0.21	38
Enteral system				
Jejunum → ileum	1.4	1–3	1.8	41, 60
Ileum → colon	0.3	0.2–1	0.75	85
Colon → out	0.04	0–0.5	0	85
Circulatory system (plasma)				
Mesenteric arterial	600	500–700	660	83, 86
Portal systemic (shunt)	0	0	0	
Portal venous	600	500–700	660	83, 86
Hepatic arterial	250	200–300	240	83, 86
Hepatic venous	800	700–1,000	900	83, 86

Values for fasting conditions (all chl species).

Presumed range, for fasting normal subjects at steady state.

Derived values, at steady state in fasting condition (0700).

° Assumption of the model.

TABLE V  
Bile Acid Fluxes Caused by Flows:° Published Data and Values Used in Simulation

	Published	Presumed range	Obtained values	References
	<i>nmol/min, average mean value</i>	<i>nmol/min</i>		
Hepatobiliary system				
Bile ducts → gallbladder	1,000	500–2,000	950	47
Gallbladder → bile ducts	0	0	0	†
Bile ducts → jejunum	2,000	1,000–3,000	2,200	37, 38
Enteral system				
Jejunum → ileum	2,500	1,000–5,000	2,700	29, 60
Ileum → colon	1,000	200–2,000	230	85
Colon → out (as fecal output)	0	0	0	†
Circulatory system				
Mesenteric arterial	§	—	0.20	§
Portal-systemic shunt	§	—	0	§
Portal	§	—	1.41	§
Hepatic arterial	§	—	0.17	§
Hepatic venous	§	—	0.08	§

° Values for fasting conditions (all chl species).

† Assumption of the model (see text). Presumed range, for fasting normal subjects at steady state. Derived values, at steady state in fasting condition (0700).

§ Not available.

tion-correction methods) (69) would require quite long computing time. The time of the integration step, for example, must be of the order of  $10^{-2}$  min and the number of integration steps for a 14-d simulation, usually necessary to be sure to be at steady state, is of the order of  $2 \times 10^6$ . This, for example, results in a computing time of  $\sim 800$  min on the computer HP 21 mx we used.

In order to shorten the necessary computing time, we developed a novel numerical method that took advantage of the particular structure of the model, i.e., the model is linear time invariant in different intervals of time, and has constant input (synthesis rate).

Then, in each of the intervals of time the model equations are of the type:

$$\frac{dQ(t)}{dt} = A Q(t) + B \cdot S,$$

where  $Q(t) = (Q_1, \dots, Q_n)$  is the vector whose  $i$ th component represents the amount of substance in compartment  $i$ ,  $S$  is the synthesis rate, and  $A$  and  $B$  are suitable matrices whose elements are a function of the transfer rates  $K$ . If the values of  $Q$  at given instants of time  $t_n = n t$ ,  $n = 1, 2, 3, \dots, N$  are of interest,

$$Q(t_{n+1}) = F Q(t_n) + G S,$$

where  $F$  and  $G$  can be computed as functions of the known matrices  $A$  and  $B$  (for example  $F = e^{At}$ ).

This formula allows the simulation of the model with a computing time roughly equal to half of the time of a prediction-correction method with an integration step equal to  $t$ , plus the time of computing the  $F$  and  $G$  matrices for each of the considered time intervals in which the system is assumed time invariant (65). In the present case, the number of integration steps is reduced  $\sim 100$  times, and the total computing time for a 14-d simulation is reduced to  $\sim 14$  min.

## RESULTS

The simulation was run and parameters were adjusted within physiologically acceptable ranges until the steady-state condition values obtained were in good agreement with the literature. Values for which good experimental data were available or were judged to be important were weighted more heavily.

TABLE VI  
Bile Acid Fluxes Caused by Biotransformation (Flux): Published and Obtained Values\*

	Published, average mean value	Presumed range	Obtained values	References
	<i>nmol/min</i>	<i>nmol/min</i>		
Hepatobiliary system				
Conjugation				
chl $\rightarrow$ chl-gly	2,200†	500–1,500	630	14, 16
chl $\rightarrow$ chl-tau	280	100–1,000	210	15, 16
Sulfation				
chl-gly $\rightarrow$ sul-chl-gly	0	0	0	36, 51, 52
chl-gly $\rightarrow$ sul-chl-tau	0	0	0	36, 51, 52
Enteral system				
Deconjugation, jejunal				
chl-gly $\rightarrow$ chl	0	0	0	§
chl-tau $\rightarrow$ chl	0	0	0	§
Deconjugation, ileal				
chl-gly $\rightarrow$ chl		200–1,000†	310	14, 16
chl-tau $\rightarrow$ chl		50–250†	100	15, 16
Deconjugation, colonic				
chl-gly $\rightarrow$ chl		—	160	§
chl-tau $\rightarrow$ chl		—	60	§
Dehydroxylation, colonic				
chl $\rightarrow$ dex	500	200–600	230¶	

Values for fasting conditions. Abbreviations: See Table II; sul = sulfo; dex = deoxycholic.

† Includes meals [based on model (16) with greater deconjugation of cholylglycine].

§ Assumptions of the model.

|| Not available.

¶ Not equal to synthesis, because meal dependent. Presumed range, for fasting normal subjects at steady state. Obtained values, at steady state in fasting condition (0800).

Table II summarizes the published data for average mean values for bile acid concentration, as well as presumed ranges. The values obtained in the final simulation are given, as well as the references from which the published data were obtained. The product of the volumes given in Table I and the concentrations in Table II are the mass of bile acids in a given compartment in the fasting state.

Table III summarizes the transfer coefficients used in the final simulation. The relative values of transfer coefficients for fluxes out of individual compartments are shown in Fig. 4; for each compartment, the sum of the fluxes is 1.0.

Table IV summarizes the volume flows in the final simulation. These values are in fact "derived values" since they are the product of a given volume (Table I) and its respective transfer coefficient (Table III).

Tables V, VI, and VII summarize published values

for bile acid fluxes as well as the values obtained in the final simulation. Table V summarizes bile acid flux caused by "flows"; Table VI, by biotransformations, i.e., the nanomoles per minute of bile acid undergoing conjugation, reconjugation, deconjugation, or dehydroxylation; and Table VII, by transport, i.e., movement into and out of the hepatocyte or out of the intestinal lumen.

The successful simulation gave values for the bile acid mass in each compartment in relation to time. Figs. 5 and 6 show typical printouts from the computer. The printout in Fig. 5 shows the time course of bile acid secretion into the intestine, i.e., from the gallbladder and bile duct compartment, in relation to meals. Fig. 6 shows the time course of serum bile acid levels in relation to meals. Table VIII summarizes the mass in each compartment during the fasting state and during and after a meal.

TABLE VII  
*Bile Acid Fluxes Caused by Transport: Published and Obtained Values*

	Published, average mean value	Presumed range	Obtained values	References
	<i>nmol/min</i>	<i>nmol/min</i>		
<b>Hepatobiliary System</b>				
Hepatic uptake (sinusoid → liver)				
chl-gly	°	—	2,700	°
chl-tau	°	—	950	°
chl	°	—	1,500	°
Reflux from liver (liver → sinusoid)				
chl-gly	°	—	1,100	°
chl-tau	°	—	390	°
chl	°	—	1,050	°
Biliary secretion (liver → bile ducts)				
chl-gly	3,000 (18,000)	2,000–6,000	2,200	38
chl-tau	1,000 (6,000)	500–2,000	780	38
chl	0	0	0	†
<b>Enteral System§</b>				
Ileal absorption (ileum → portal)				
chl-gly	3,000 (18,000)	2,000–4,000	1,550	37
chl-tau	1,000 (6,000)	500–1,800	560	37
chl		200–600	400	62

Values for fasting condition, values for digestion are given in parentheses.

° Not available.

† Assumptions of the model.

Presumed range, for fasting normal subjects at steady state.

Obtained values, at steady state in fasting condition (0700).

§ Jejunal absorption and colonic absorption omitted from table as simulation assumed no absorption of any chl species from jejunum, and all chl species passing into colon are immediately and fully dehydroxylated to deoxycholyl species.

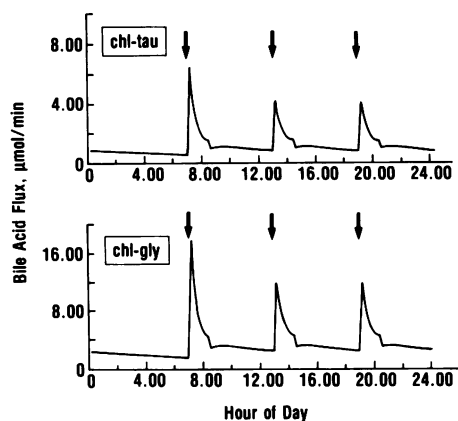

FIGURE 5 Time course of secretion of chl-tau and chl-gly into the jejunum (compartments 7.1 and 7.3), as depicted in the computer printout of the simulation. The vertical arrows indicate the ingestion of "meals" at 0700, 1300, and 1900 h that initiated gallbladder contraction. The rates of peak intestinal secretion, 2–7  $\mu\text{mol}/\text{min}$ , are within the range of values reported for healthy individuals during digestion (37, 38).

It is clear that the values obtained by simulation depicted here and tabulated in the tables agree satisfactorily with the values in the published literature.

## DISCUSSION

This paper reports the first complete description of cholic acid metabolism in man and may well be the first physiological pharmacokinetic model for a group of endogenous compounds undergoing an extensive enterohepatic circulation. The model satisfactorily simulates all available experimental data. Every space compartment and transfer coefficient has been defined and justified from a physiological standpoint.

*Aggregation of spaces.* In the model, some anatomical spaces and fluxes have been aggregated or omitted in the interest of simplicity.

From a transport point of view, the sinusoid and hepatocyte have each been lumped into a single compartment and an enterocyte space has been omitted. For symmetry, the hepatocyte and enterocyte should in principle be treated analogously. Thus the sinusoidal space is analogous to an intraluminal space; the hepatocyte space is analogous to the enterocyte space; and the bile duct space is analogous to the portal space. In each instance, the cell is the interface between a high-flow blood-filled compartment and a low-flow biliary compartment. Justification for the choice of three enteral spaces has been given.

From a biotransformation point of view, we have elected to omit consideration of the dehydrogenation

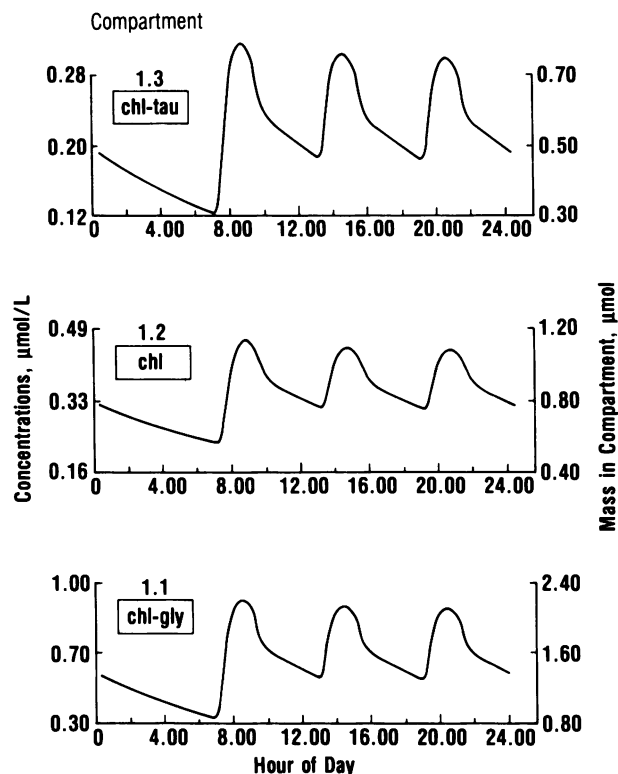

FIGURE 6 Time course of bile acid concentrations in the systemic circulatory compartments, as depicted in the computer printout. Upper panel shows chl-tau (compartment 1.3); center panel, unconjugated cholic acid (compartment 1.2); and lower panel, chl-gly (compartment 1.1). The peaks correspond to the postprandial elevation occurring after meals that were ingested at 0700, 1300, and 1900 h. Gallbladder contraction is initiated at the ingestion of a meal causing increased bile acid secretion into the intestine, which in turn is followed by increased levels of bile acids in peripheral blood, as depicted here. The postprandial peak of choly conjugates (chl-gly plus chl-tau) occurs at  $\sim 2$  h postprandially and rises to 2.7  $\mu\text{mol}/\text{liter}$ , which is in the range of reported values (22–25).

of cholic acid by intestinal bacteria to form its 7-keto derivative.<sup>8</sup>

From a flow point of view, we have greatly simplified the bile duct system. It is probably desirable to have not only a hepatic duct space but also a (common) bile duct space.

*Utility of the model.* This paper has as its aim the development of the principles of the model together with sufficient simulation to show that the theoretical model that has been developed on physiological prin-

<sup>8</sup> The formation of 7-ketodeoxycholic acid is not considered to have physiological significance, as any 7-ketodeoxycholic acid absorbed from the intestine is likely to be reduced to mostly cholic acid during hepatic passage (70, 71).



TABLE VIII  
Diurnal Variation of Bile Acid Content of Compartments Obtained by Simulation,  $\mu\text{mol}^*$

Space	0000 (12 midnight)			0700			0830*			1000			1200 (Noon)		
	chl-gly	chl-tau	chl	chl-gly	chl-tau	chl	chl-gly	chl-tau	chl	chl-gly	chl-tau	chl	chl-gly	chl-tau	chl
Hepatic	17	5.9	14	11	3.9	11	27	9.3	18	20	7.1	16	17	6.1	14
Bile duct	246	86	0	160	55	0	250	89	0	300	100	0	250	88	0
Gallbladder	300	108	0	680	240	0	47	17	0	160	58	0	310	110	0
Jejunal	540	190	0	330	120	0	780	270	0	640	220	0	550	190	0
Ileal	51	18	6.5	31	11	4	85	30	11	61	22	7.8	52	19	66
Colonic	0.05	0.018	0.38	0.03	0.01	0.23	0.1	0.036	0.76	0.061	0.022	0.45	0.052	0.019	0.39
Systemic	1.4	0.49	0.8	0.87	0.3	0.56	2.2	0.8	1.1	1.6	0.58	0.93	1.4	0.50	0.8
Portal	1.9	0.66	0.55	1.1	0.4	0.35	3	1.1	0.86	2.2	0.80	0.66	1.9	0.68	0.56
Sinusoidal	0.07	0.024	0.038	0.04	0.015	0.03	0.1	0.04	0.056	0.08	0.028	0.045	0.068	0.024	0.039
Total	1160	410	22	1210	425	16	1190	420	31	1180	420	26	1190	420	22
Total pool		1,590			1,660			1,640			1,630			1,630	

\* All values have been rounded off in the summations.

ciples can be simulated to give results that are not in gross disagreement with experimental values. Experimental values, especially the time course of biliary secretion and plasma levels, could have been simulated perfectly by appropriate adjustment of parameters, but such fitting has little utility. The amount of precise experimental data on intestinal bile acid absorption in man is so limited that in many cases the values assumed were just "guesses".

Despite the considerable limitations in available experimental data, we believe that this model should have considerable utility. First, the model embodies in a complete, synthetic, and integrated manner much previous experimental information on cholic acid metabolism. It should be possible to verify the "self-consistency" of uncertain information obtained from different experimental approaches.

Second, the model allows the quantitative evaluation of the effects on bile acid concentrations caused by physiological events. For example, the model predicts that the serum level of bile acids in the general circulation is largely determined by the spillover from the sinusoidal space. It is clear from the model that the spillover is determined by the ratio between a flow and a transport [sinusoid  $\rightarrow$  liver (cell)] coefficient. These same coefficients also determine the plasma clearance of intravenously injected bile acids. In addition, the model indicates that serum should always contain levels of unconjugated cholic acid resulting from deconjugation by intestinal bacteria, as has recently been shown experimentally (50). The model makes possible the evaluation of the levels in compartments not easily accessible for measurements.

Third, the model can be used to assess the adequacy

of existing experimental data and to aid in the design of new experimental conditions needed for a more accurate estimation of as yet poorly defined parameters.

Fourth, the model should allow prediction of the pharmacokinetic behavior of bile acid loads. For example, the spillover into the systemic circulation of an oral bile acid load is influenced largely by the transport coefficient of liver uptake unless there is portal systemic shunting. Thus, the simplest way to present a defined load to the liver is by administering a bile acid orally that is rapidly and passively absorbed from the jejunum (72, 73).

Fifth, the model can be used also to predict the behavior of cholic acid metabolism in some pathological conditions (cf. 58). In particular, it allows a better interpretation of some laboratory findings used for diagnosis. For example, an increase in the level of unconjugated cholic acid would be caused by increased deconjugation in the intestine; these high serum levels could be erroneously interpreted as indicating liver disease if an analytical method was used that did not distinguish individual cholic acid species, i.e., unconjugated or conjugated.

Finally, the model may be used to categorize disturbances in the enterohepatic circulation of cholic acid induced by drugs or caused by digestive disease. In Table IX, we have classified perturbations of the enterohepatic circulation according to the model. The model may be used to predict the effect of these perturbations on masses and fluxes of bile acids, and thus rationalize changes in serum bile acid levels.

The model described in this paper is similar in purpose to a number of physiological pharmacokinetic

TABLE IX  
*Perturbations of the Enterohepatic Circulation of Bile Acids*

Classification according to MEHCCA	Clinical instance	Altered transfer coefficients*
<b>Altered input</b>		
Bile acid feeding	Cholic acid feeding	$f_{47}$
<b>Altered flow coefficients</b>		
Delayed gallbladder emptying	Gallbladder disease	$f_{23}$
Absence of gallbladder storage	Post cholecystectomy	$f_{22}, f_{24}$
Increased intestinal transit	Irritable bowel syndrome	$f_{30}, f_{31}, f_{37}, f_{38}$
Portal-systemic shunting	Portal vein thrombosis or portal cirrhosis	$f_2$
Obstruction to bile flow into jejunum	Common bile duct obstruction	$f_{24}$
<b>Altered transport coefficients</b>		
Impaired hepatic uptake	Parenchymal liver disease	$t_9, t_{10}, t_{11}$
Impaired secretion into bile	Cholestasis	$t_{19}, t_{20}, t_{21}$
Decreased intestinal absorption	Intraluminal binding by cholestyramine	$t_{25}, t_{26}, t_{27}, t_{32}, t_{33}, t_{34}$
Impaired active absorption	Ileal dysfunction or resection	$t_{32}, t_{33}, t_{34}$
<b>Altered biotransformation coefficients</b>		
<b>Hepatic</b>		
Impaired conjugation	Hepatic failure	$b_{15}, b_{16}$
Increased conjugation with taurine	Taurine feeding	$b_{16}$
<b>Enteric</b>		
Increased sulfation	Cholestasis	$b_{17}, b_{18}$
Increased deconjugation in jejunum	Stagnant loop syndrome	$b_{28}, b_{29}$
Increased deconjugation in ileum	Ileal obstruction, e.g. in Crohn's disease	$b_{35}, b_{36}$
<b>Combined alterations</b>		
Impaired hepatic uptake and portal systemic shunts	Cirrhosis	$t_9, t_{10}, t_{11}$ $f_2, b_{17}, b_{18}$
Increased renal excretion	Cholestasis	$m_6, m_7, m_8$

\* The transfer coefficient listed is the first transfer coefficient which is altered by the perturbation. Each condition may in time lead to a new steady state with different values for spaces or transfer coefficients or both.

models that were based on the pioneering work of Bischoff and Dedrick on thiopental pharmacokinetics (74) who applied concepts of process analysis and simulation derived from chemical engineering (75) to drug pharmacokinetics. This work has been expanded from the initial flow-limited models (76) to include membrane-limited models (reviewed in 46), as well as biotransformations (77), biliary secretion (78), and drug interactions (79). Both the approach of Bischoff and Dedrick and our approach have sought to develop global models in which compartments and fluxes have anatomical meanings. While our work was in progress, this group extended their modeling to the gastrointestinal tract of the rat (80). Of course, one major difference is that our work is concerned with rationalizing the behavior of an endogenous substance. As we have pointed out elsewhere (81), the identical pharmacokinetic principles should apply equally to endogenous substances, such as bile acids, vitamins, and steroids, or exogenous molecules, such as drugs. The challenge

now is to develop friendly software that will permit such physiological pharmacokinetic approaches to be used widely by the biomedical community.

#### ACKNOWLEDGMENTS

We acknowledge helpful discussions or provision of unpublished data from Dr. Andre Blum, Dr. Konrad Soergel, Dr. V. L. W. Go, and Dr. Juan Malagelada. Collation of the data used in the simulation was a difficult task, and, as noted, experimental data could not be found for all values. We would be grateful to our colleagues in the enterosciences for pointing out any errors or identifying new and relevant data. We also acknowledge the excellent editing assistance of Vicky Huebner.

The computer program used in this simulation is available at cost. For information, write to Gustavo Belforte. The program for printing the time-dependent values (as shown in Figs. 5 and 6) is machine dependent, and a general program is not available at this time.

Research at the University of California was supported by National Institutes of Health grant AM 21506, as well as grants-in-aid from the William H. Rorer Inc., Canada Pack-

ers Corporation, Eli Lilly and Co., Indianapolis, IN, and the Falk Foundation. Research at the Università di Torino and the Politecnico di Torino was supported by grants from Consiglio Nazionale delle Ricerche. Completion of this paper was made possible by a Scholar-in-Residence Award to Dr. Hofmann at the Bellagio Conference Center of the Rockefeller Foundation in Bellagio, Italy.

## REFERENCES

1. Patton, J. S. 1981. Gastrointestinal lipid digestion. *In* Physiology of the Gastrointestinal Tract. L. R. Johnson, editor. Raven Press, New York. pp. 1123-1146.
2. Thomson, A. B. R., and J. M. Dietschy. 1981. Intestinal lipid absorption. *In* Physiology of the Gastrointestinal Tract. L. R. Johnson, editor. Raven Press, New York. pp. 1147-1220.
3. Schoenfield, L. J., J. M. Lachin, the NCGS Steering Committee, and the NCGS Group. 1981. National cooperative gallstone study: a controlled trial of the efficacy and safety of chenodeoxycholic acid for dissolution of gallstones. *Ann. Intern. Med.* **95**: 257-282.
4. Bachrach, W. H., and A. F. Hofmann. 1982. Ursodeoxycholic acid in the treatment of cholesterol cholelithiasis. A review. *Dig. Dis. Sci.* **27**: 737-761, 833-856.
5. Balistreri, W. F., F. J. Suchy, and J. E. Heubi. 1980. Serum bile acid response to a test meal stimulus: a sensitive test of ileal function. *J. Pediatr.* **96**: 582-594.
6. Skrede, S., H. E. Solberg, J. P. Blomhoff, and E. Gjone. 1978. Bile acids measured in serum during fasting as a test for liver disease. *Clin. Chem.* **24**: 1095-1099.
7. Josephson, B. 1941. The circulation of the bile acids in connection with their production, conjugation, and excretion. *Physiol. Rev.* **21**: 463-486.
8. Bergstrom, S. 1962. Metabolism of bile acids. *Fed. Proc.* **21**: 28-32.
9. Lindstedt, S. 1957. The turnover of cholic acid in man. *Acta Physiol. Scand.* **40**: 1-9.
10. Vlahcevic, Z. R., J. R. Miller, J. T. Farrar, and L. Swell. 1971. Kinetics and pool size of primary bile acids in man. *Gastroenterology.* **61**: 85-90.
11. Einarsson, K., and K. Hellstrom. 1972. The formation of bile acids in patients with three types of hyperlipoproteinemia. *Eur. J. Clin. Invest.* **2**: 225-230.
12. Hepner, G. W., A. F. Hofmann, and P. J. Thomas. 1972. Metabolism of steroid and amino acid moieties of conjugated bile acids in man. II. Glycine-conjugated dihydroxy bile acids. *J. Clin. Invest.* **51**: 1898-1905.
13. Einarsson, K., and K. Hellstrom. 1974. The formation of deoxycholic acid and chenodeoxycholic acid in man. *Clin. Sci. Mol. Med.* **46**: 183-190.
14. Hepner, G. W., A. F. Hofmann, and P. J. Thomas. 1972. Metabolism of steroid and amino acid moieties of conjugated bile acids in man. I. Cholyl glycine (glycocholic acid). *J. Clin. Invest.* **51**: 1889-1897.
15. Hepner, G. W., J. A. Sturman, A. F. Hofmann, and P. J. Thomas. 1973. Metabolism of steroid and amino acid moieties of conjugated bile acids in man. III. Cholyl taurine (taurocholic acid). *J. Clin. Invest.* **52**: 433-440.
16. Hoffman, N. E., and A. F. Hofmann. 1974. Metabolism of steroid and amino acid moieties of conjugated bile acids in man. IV. Description and validation of a multicompartmental model. *Gastroenterology.* **67**: 887-897.
17. Hoffman, N. E., and A. F. Hofmann. 1977. Metabolism of steroid and amino acid moieties of conjugated bile acids in man. V. Equations for the perturbed enterohepatic circulation and their application. *Gastroenterology.* **72**: 141-148.
18. Simmonds, W. J., M. G. Korman, V. L. W. Go, and A. F. Hofmann. 1973. Radioimmunoassay of conjugated cholyl bile acids in serum. *Gastroenterology.* **65**: 705-711.
19. Schalm, S. W., G. P. van Berge Henegouwen, A. F. Hofmann, A. E. Cowen, and J. Turcotte. 1977. Radioimmunoassay of serum bile acids. II. Development, validation and preliminary application of an assay for conjugates of chenodeoxycholic acid. *Gastroenterology.* **73**: 285-290.
20. Roda, A., E. Roda, R. Aldini, D. Festi, G. Mazzella, C. Sama, and L. Barbara. 1977. Development, validation, and application of a single-tube radioimmunoassay for cholic and chenodeoxycholic conjugated bile acids in human serum. *Clin. Chem.* **23**: 2107-2113.
21. Murphy, G. M., S. M. Edkins, J. W. Williams, and D. Catty. 1974. The preparation and properties of an antiserum for the radioimmunoassay of serum conjugated cholic acid. *Clin. Chim. Acta.* **54**: 81-89.
22. LaRusso, N. F., M. G. Korman, N. E. Hoffman, and A. F. Hofmann. 1974. Dynamics of the enterohepatic circulation of bile acids. *N. Engl. J. Med.* **291**: 689-692.
23. Schalm, S. W., N. F. LaRusso, A. F. Hofmann, N. E. Hoffman, G. P. van Berge Henegouwen, and M. G. Korman. 1978. Diurnal serum levels of primary conjugated bile acids. Assessment by specific radioimmunoassays for conjugates of cholic and chenodeoxycholic acid. *Gut.* **19**: 1006-1014.
24. Ponz de Leon, M., G. M. Murphy, and R. H. Dowling. 1978. Physiological factors influencing serum bile acid levels. *Gut.* **19**: 32-39.
25. Barbara, L., A. Roda, E. Roda, R. Aldini, G. Mazzella, D. Festi, and C. Sama. 1976. Diurnal variations of serum primary bile acids in healthy subjects and hepatobiliary disease patients. *Rend. Gastroenterol.* **8**: 194-198.
26. Pries, J. M., C. A. Sherman, G. C. Williams, and R. Hanson. 1979. Hepatic excretion of bile salts in conscious dog. *Am. J. Physiol.* **236**: E191-E197.
27. Pries, J. M., A. B. Staples, and R. F. Hanson. 1981. The effect of hepatic blood flow on taurocholate extraction by the isolated perfused rat liver. *J. Lab. Clin. Med.* **97**: 412-417.
28. Gilmore, I. T., and R. P. H. Thompson. 1978. Kinetics of <sup>14</sup>C-glycocholic acid clearance in normal man and in patients with liver disease. *Gut.* **19**: 1110-1115.
29. LaRusso, N. F., N. E. Hoffman, M. G. Korman, A. F. Hofmann, and A. E. Cowen. 1978. Determinants of fasting and postprandial serum bile acid levels in healthy man. *Am. J. Dig. Dis.* **23**: 385-391.
30. Hofmann, A. F., N. F. LaRusso, and G. P. van Berge Henegouwen. 1977. Serum bile acid levels: a compartmental model for the dynamics of the enterohepatic circulation. *In* Bile Acid Metabolism in Health and Disease. G. Paumgartner and A. Stiehl, editors. MTP Press, Lancaster, England. pp. 151-156.
31. Hofmann, A. F. 1977. The enterohepatic circulation of conjugated bile acids in healthy man: quantitative description and functions. *In* Cholesterol Metabolism and Lipolytic Enzymes. J. Polonovski, editor. Masson Publishing Inc., New York. pp. 69-86.
32. Hofmann, A. F. 1978-1979. The medical treatment of gallstones: a clinical application for the new biology of bile acids. Harvey Lectures, 1978-1979, Series 74. pp. 23-48.
33. Molino, G., and M. Milanese. 1975. Structural analysis

- of compartmental models for the hepatic kinetics of drugs. *J. Lab. Clin. Med.* **85**: 865-878.
34. Molino, G., and M. Milanese. 1982. Modeling of hepatobiliary transport processes: bromsulphthalein and bilirubin kinetics. In *The Role of Tracers and Models in Clinical Medicine*. D. G. Cramp, editor. John Wiley and Sons, Chichester, England. pp. 185-217.
  35. Atkins, G. L. 1969. *Multicompartment Models in Biological Systems*. Methuen and Company, Ltd., London, England. pp. 153.
  36. van Berge Henegouwen, G. P., K.-H. Brandt, H. Eysen, and G. Parmentier. 1976. Sulfated and unsulfated bile acids in serum, bile, and urine of patients with cholestasis. *Gut*. **17**: 861-869.
  37. Northfield, T. C., and A. F. Hofmann. 1975. Biliary lipid output during three meals and an overnight fast. I. Relationship to bile acid pool size and cholesterol saturation of bile in gallstone and control subjects. *Gut*. **16**: 1-11.
  38. van Berge Henegouwen, G. P., and A. F. Hofmann. 1978. Nocturnal gallbladder storage and emptying in gallstone patients and healthy subjects. *Gastroenterology*. **75**: 879-885.
  39. Peeters, T. L., G. Vantrappen, and J. Janssens. 1980. Bile acid output and the interdigestive migrating motor complex in normals and in cholecystectomized patients. *Gastroenterology*. **79**: 678-681.
  40. Grundy, S. M., and A. L. Metzger. 1972. A physiologic method for estimation of hepatic secretion of biliary lipids in man. *Gastroenterology*. **62**: 1200-1217.
  41. Kerlin, P., A. Zinsmeister, and S. Phillips. 1982. Relationship of motility to flow of contents in the human small intestine. *Gastroenterology*. **82**: 701-706.
  42. Low-Beer, T. S., K. W. Heaton, S. T. Heaton, and A. E. Readd. 1971. Gallbladder inertia and sluggish enterohepatic circulation of bile salts in coeliac disease. *Lancet*. **I**: 991-994.
  43. Duane, W. C., M. L. Gilberstadt, and D. M. Weigand. 1979. Diurnal rhythms of bile acid production in the rat. *Am. J. Physiol.* **236**: R175-R179.
  44. Chevallier, F., and C. Lutton. 1966. Cinetiques journaliere et horaire de la transformation du cholesterol-26-<sup>14</sup>C en acides biliaries. *Bull. Soc. Chim. Biol.* **48**: 295-311.
  45. Forker, E. L., and B. Luxon. 1978. Hepatic transport kinetics and plasma disappearance curves: distributed modeling versus conventional approach. *Am. J. Physiol.* **235**: E648-E660.
  46. Lutz, R. J., R. L. Dedrick, and D. S. Zaharko. 1980. Physiological pharmacokinetics: An in vivo approach to membrane transport. *Pharmacol. Ther.* **11**: 559-592.
  47. Everson, G. T., D. Z. Braverman, M. L. Johnson, and F. Kern, Jr. 1980. A critical evaluation of real-time ultrasonography for the study of gallbladder volume and contraction. *Gastroenterology*. **79**: 40-46.
  48. Cowen, A. E., M. G. Korman, A. F. Hofmann, and O. W. Cass. 1975. Metabolism of lithocholate in man. I. Biotransformation and biliary excretion of intravenously administered lithocholate, lithocholylcysteine, and their sulfates. *Gastroenterology*. **69**: 59-66.
  49. Hardison, W. G. M. 1978. Hepatic taurine concentration and dietary taurine as regulators of bile acid conjugation with taurine. *Gastroenterology*. **75**: 71-75.
  50. Setchell, K. D. R., A. M. Lawson, E. J. Blackstock, and G. M. Murphy. 1982. Diurnal changes in serum unconjugated bile acids in normal man. *Gut*. **23**: 637-642.
  51. Makino, I., H. Hashimoto, K. Shinozaki, K. Yoshino, and H. Nakagawa. 1975. Sulfated and nonsulfated bile acids in urine, serum, and bile of patients with hepatobiliary diseases. *Gastroenterology*. **68**: 545-553.
  52. Stiehl, A., D. L. Earnest, and W. H. Admirand. 1975. Sulfation and renal excretion of bile salts in patients with cirrhosis of the liver. *Gastroenterology*. **68**: 534-544.
  53. Gilmore, I. T., and R. P. H. Thompson. 1978. Direct measurement of the first pass extraction of bile acids by the liver in man. *Gut*. **19**: A971. (Abstr.)
  54. Cowen, A. E., M. G. Korman, A. F. Hofmann, and P. J. Thomas. 1975. Plasma disappearance of radioactivity after intravenous injection of labeled bile acids in man. *Gastroenterology*. **68**: 1567-1573.
  55. Stahl, E., and B. Arnesjo. 1972. Taurocholate metabolism in man. *Scand. J. Gastroenterol.* **7**: 559-566.
  56. Greim, H., P. Czygan, F. Schaffner, and H. Popper. 1973. Determination of bile acids in needle biopsies of human liver. *Biochem. Med.* **8**: 280-286.
  57. Collins, D. M., J. H. T. Bates, A. H. Maslowski, A. E. McKinnon, and C. B. Campbell. 1981. The extent of reflux of unconjugated <sup>14</sup>C-cholic acid from the liver in subjects with normal liver function. *Aust. J. Exp. Biol. Med. Sci.* **59**: 779-790.
  58. Horak, W., R. Waldram, I. M. Murray-Lyon, E. Schuster, and R. Williams. 1976. Kinetics of <sup>14</sup>C-cholic acid in fulminant hepatic failure: a prognostic test. *Gastroenterology*. **71**: 809-813.
  59. Morselli, A. M., M. Milanese, G. P. Molino, G. Belforte, A. Roda, E. Roda, and A. Cavallari. 1980. Accuracy of the evaluation of the bile acid hepatobiliary kinetics by compartmental analysis in normal and cholestatic baboons. *Ital. J. Gastroenterol.* **12**: 124-127.
  60. Soergel, K. H. 1969. Flow measurements of test meals and fasting contents in the human small intestine. In *Gastrointestinal Motility International Symposium*. Erlangen: Georg Thieme Verlag, Stuttgart, W. Germany. pp. 81-95.
  61. Tanida, N., Y. Hikasa, M. Hosomi, M. Satomi, I. Oohama, and T. Shimoyama. 1981. Fecal bile acid analysis in healthy Japanese subjects using a lipophilic anion exchanger, capillary column gas chromatography and mass spectrometry. *Gastroenterol. Jpn.* **16**: 363-371.
  62. Mekhjian, H. S., S. F. Phillips, and A. F. Hofmann. 1979. Colonic absorption of unconjugated bile acids: perfusion studies in man. *Am. J. Dig. Dis.* **24**: 545-550.
  63. Hofmann, A. F. 1977. The enterohepatic circulation of bile acids in man. *Clin. Gastroenterol.* **6**: 3-24.
  64. Gilmore, I. T., and R. P. H. Thompson. 1980. Plasma clearance of oral and intravenous cholic acid in subjects with and without chronic liver disease. *Gut*. **21**: 123-127.
  65. Milanese, M., G. Molino, and F. Cappelletti. 1981. New results on saturation phenomena in BSP metabolism: the role of free and conjugated BSP. *Med. Biol. Eng. Comput.* **19**: 707-716.
  66. Milanese, M., and G. Belforte. 1978. The parameter aggregation approach in improving the identifiability properties of large systems. In *Proceedings of the Second International Symposium on Large Engineering Systems*. G. J. Savage, P. H. Roe, editors. Sanford Educational Press, Waterloo, Canada. **2**: 561-565.
  67. Milanese, M., and G. Belforte. 1981. Structural problems in identification, state estimation and aggregation. *Large Scale Systems: Theory & Application*. **2**: 97-104.
  68. Genesio, R., and M. Milanese. 1979. Methods for the selection of and approximating classes of models. In *Vth IFAC Symposium on Identification and System Param-*

- eter Estimation. R. Isermann, editor. Pergamon Press, New York. 1: 549-560.
69. Ralston, A., and H. S. Wilf. 1967. *Mathematical Methods for Digital Computers*. John Wiley & Sons, Inc., New York.
  70. Fromm, H., S. Farivar, A. F. Hofmann, G. L. Carlson, and P. Amin. 1980. Metabolism in man of 7-ketolithocholic acid, a major secondary bile acid. *Am. J. Physiol.* **239**: G161-G166.
  71. Danzinger, R. G., A. F. Hofmann, R. A. DiPietro, E. B. Ljungwe, and J. L. Barnhart. 1981. Metabolism and physiological properties of two 7-keto bile acids in the dog. *Hepatology*. **1**: 505. (Abstr.)
  72. Okhubo, H., K. Okuda, S. Iida, and I. Makino. 1981. Ursodeoxycholic acid oral tolerance test in patients with constitutional hyperbilirubinemia and effect of phenobarbital. *Gastroenterology*. **81**: 126-135.
  73. Shinozaki, K. 1979. Pharmacokinetic study of ursodeoxycholic acid tolerance test. *Acta Hepatol. Jpn.* **20**: 782-794.
  74. Bischoff, K. B., and R. L. Dedrick. 1968. Thiopental pharmacokinetics. *J. Pharm. Sci.* **8**: 1346-1351.
  75. Himmelblau, D. M., and K. B. Bischoff. 1968. *Process Analysis and Stimulation*. John Wiley & Sons, Inc., New York.
  76. Bischoff, K. B., R. L. Dedrick, D. S. Zaharko, and J. A. Longstreth. 1971. Methotrexate pharmacokinetics. *J. Pharm. Sci.* **60**: 1128-1133.
  77. Dedrick, R. L., D. D. Forrester, J. N. Cannon, S. M. ElDareer, and L. B. Mellett. 1973. Pharmacokinetics of 1-D-arabinofuranosylcytosine (ara-C) deamination in several species. *Biochem. Pharmacol.* **22**: 2405-2417.
  78. Bungay, P. M., R. L. Dedrick, and A. M. Guarino. 1976. Pharmacokinetic modeling of the dogfish shark (*squalus acanthias*): distribution and urinary and biliary excretion of phenol red and its glucuronide. *J. Pharmacokinet. Biopharm.* **4**: 377-388.
  79. Luecke, R. H., and W. D. Wosilait. 1979. Drug elimination interactions: analysis using a mathematical model. *J. Pharmacokinet. Biopharm.* **7**: 629-641.
  80. Bungay, P. M., R. L. Dedrick, and H. B. Matthews. 1980. Enteric transport of chlordecone (Kepone) in the rat. *J. Pharmacokinet. Biopharm.* **9**: 309-340.
  81. Gilmore, I. T., and A. F. Hofmann. 1980. Altered drug metabolism and elevated serum bile acids in liver disease: a unified pharmacokinetic explanation. *Gastroenterology*. **78**: 177-179.
  82. Sherlock, S. 1981. *Diseases of the Liver and Biliary System*. Blackwell Scientific Publications, Oxford. 536 pp.
  83. Wheeler, H. O. 1968. Water and electrolytes in bile. *Handb. Physiol.* **6**: 2409-2431.
  84. Devroede, G., and S. F. Phillips. 1969. Studies of the perfusion technique for colonic absorption. *Gastroenterology*. **56**: 92-100.
  85. Giller, J., and S. F. Phillips. 1973. The contribution of the colon to electrolyte and water conservation in man. *J. Lab. Clin. Med.* **81**: 733-746.
  86. Guyton, A. C. 1980. *Textbook of Medical Physiology*. W. B. Saunders Company, Philadelphia. 6th edition. pp. 709.
  87. Goresky, C. A. 1963. A linear method for determining liver sinusoidal and extravascular volumes. *Am. J. Physiol.* **204**: 626-640.
  88. Carey, M. C., and D. M. Small. 1978. The physical chemistry of cholesterol solubility in bile. Relationship to gallstone formation and dissolution in man. *J. Clin. Invest.* **61**: 998-1026.
  89. Holzbach, R. T., M. Marsh, M. Olszewski, and K. Holan. 1973. Cholesterol solubility in bile. Evidence that supersaturated bile is frequent in healthy man. *J. Clin. Invest.* **52**: 1467-1479.
  90. Go, V. L. W., J. R. Poley, A. F. Hofmann, and W. H. J. Summerskill. 1970. Disturbances in fat digestion induced by acidic jejunal pH due to gastric hypersecretion in man. *Gastroenterology*. **58**: 638-646.
  91. Northfield, T. C., and I. McColl. 1973. Postprandial concentrations of free and conjugated bile acids down the length of the normal human small intestine. *Gut*. **14**: 513-518.
  92. Mallory, A., F. Kern Jr, J. Smith, and D. Savage. 1973. Patterns of bile acids and microflora in the human small intestine. I. Bile acids. *Gastroenterology*. **64**: 26-33.
  93. McJunkin, B., H. Fromm, R. P. Sarva, and P. Amin. 1980. Factors in the mechanism of diarrhea in bile acid malabsorption. Fecal pH a key determinant. *Gastroenterology*. **80**: 1454-1464.
  94. Ahlberg, J., B. Angelin, I. Bjorkhem, and K. Einarsson. 1977. Individual bile acids in portal venous and systemic blood serum of fasting man. *Gastroenterology*. **73**: 1377-1382.