

Antibodies to human caudate nucleus neurons in Huntington's chorea.

G Husby, ... , E Kokmen, R C Williams Jr

J Clin Invest. 1977;59(5):922-932. <https://doi.org/10.1172/JCI108714>.

Research Article

Antibodies reacting with neuronal cytoplasmic antigens present in normal human caudate and subthalamic nuclei were detected in 37 of 80 probands afflicted with Huntington's disease (HD). IgG antibodies were detected by immunofluorescence using frozen sections of unfixed normal human and rat brain. Specificity of IgG binding was confirmed using pepsin F(ab')₂ fragments of IgG isolated from positive sera. In vitro complement fixation of IgG antibody was detected in 22 of 31 sera tested. Neuronal cytoplasmic antigens reacting with positive HD sera were diminished after trypsin or RNAase treatment of tissue sections but were not removed by DNAase, neuraminidase, EDTA, or dithiothreitol treatment. Antibody staining of neurons could be removed after absorption with isolated caudate nucleus neurons or by using perchloroacetic acid extracts of caudate nucleus. Prevalence of antibody reacting with neuronal cytoplasm was 3% in 60 normal controls and 6% among a wide variety of patients with diverse neurological disorders. However, one-third of 33 patients with Parkinson's disease showed presence of antineuronal antibody. Among patients with HD, a significant association was noted between duration of clinical disease greater than 7 yr and titers of antibody of 1:2 or greater (P less than 0.001). When 115 family members of HD probands were tested, 30% of unaffected spouses showed presence of antineuronal antibody. 23.2% of first-degree relatives at risk for developing HD [...]

Find the latest version:

<https://jci.me/108714/pdf>



Antibodies to Human Caudate Nucleus Neurons in Huntington's Chorea

GUNNAR HUSBY, LAWRENCE LI, LARRY E. DAVIS, ELISABETH WEDEGE, EMRE KOKMEN,
and RALPH C. WILLIAMS, JR.

From the Departments of Medicine and Neurology, University of New Mexico School of Medicine, and the Bernalillo County Medical Center, Albuquerque, New Mexico 87108, and the Department of Neurology, University of Michigan Medical Center, Ann Arbor, Michigan 48100

ABSTRACT Antibodies reacting with neuronal cytoplasmic antigens present in normal human caudate and subthalamic nuclei were detected in 37 of 80 probands afflicted with Huntington's disease (HD). IgG antibodies were detected by immunofluorescence using frozen sections of unfixed normal human and rat brain. Specificity of IgG binding was confirmed using pepsin F(ab')₂ fragments of IgG isolated from positive sera. In vitro complement fixation of IgG antibody was detected in 22 of 31 sera tested. Neuronal cytoplasmic antigens reacting with positive HD sera were diminished after trypsin or RNAase treatment of tissue sections but were not removed by DNAase, neuraminidase, EDTA, or dithiothreitol treatment. Antibody staining of neurons could be removed after absorption with isolated caudate nucleus neurons or by using perchloroacetic acid extracts of caudate nucleus.

Prevalence of antibody reacting with neuronal cytoplasm was 3% in 60 normal controls and 6% among a wide variety of patients with diverse neurological disorders. However, one-third of 33 patients with Parkinson's disease showed presence of antineuronal antibody. Among patients with HD, a significant association was noted between duration of clinical disease greater than 7 yr and titers of antibody of 1:2 or greater ($P < 0.001$).

When 115 family members of HD probands were tested, 30% of unaffected spouses showed presence of antineuronal antibody. 23.2% of first-degree relatives at risk for developing HD were also positive ($P < 0.001$). 10.5% of second-degree relatives showed presence of antineuronal antibody. These data may support an environmental or infectious factor somehow involved in the ultimate expression of HD.

INTRODUCTION

Huntington's disease (HD)¹ is a degenerative disease of the central nervous system which appears to be related to autosomal dominant genetic inheritance (1-5). Numerous family studies have documented the genetic distribution of this disorder, however precise insight into its etiology is not yet available. Some evidence has been accumulated relating abnormalities in central nervous system receptor mechanisms involving reduced glutamic acid decarboxylase activity or gamma aminobutyric acid (6, 7) receptors to HD, but as yet no clear idea of genesis has been presented. The present study arose from a chance observation that several sera from patients with HD contained antibodies to neuronal cytoplasmic structures which were particularly prominent in human caudate nucleus. During the course of previous work, it was found that a substantial proportion of sera from children with Sydenham's chorea showed anticaudate nucleus neuronal antibody (8, 9). In the case of these sera from children with rheumatic fever, antibody activity could be completely absorbed using purified membranes from hemolytic group A streptococci. A large number of controls, including some patients with diverse neurological diseases, was also previously studied, and no significant increase in antineuronal antibodies was recorded (9). Subsequently, several sera from patients with HD were also studied and these sera showed striking staining of neurons in frozen sections of human caudate nucleus when indirect immunofluorescence technique was used. Antibody activity from sera of HD patients was not

¹Abbreviations used in this paper: HD, Huntington's disease; PBS, phosphate-buffered saline; VCN, neuraminidase.

Received for publication 22 November 1976.

removed by streptococcal membrane absorption and it appeared that this reaction was distinct from that previously recorded in Sydenham's chorea. The present report presents findings on the prevalence of antineuronal antibodies in a large group of sera obtained from HD patients. In addition, studies of unaffected HD family members at risk as well as a group of spouses of HD patients provide fascinating possibilities regarding potential disease mechanisms in this disorder.

METHODS

Clinical material. 80 patients with clearly established HD constituted the main group studied. 18 patients hospitalized at the Albuquerque Veterans Administration Hospital or Bernalillo County Medical Center were some of the subjects studied. An additional nine affected individuals were studied through samples kindly provided by their responsible physicians throughout the country. 25 HD subjects were studied from clinical material available at Ann Arbor, Mich. and another 17 patients were drawn from patients followed through the Neurology service at the University of Colorado Medical Center. Finally, 11 HD subjects from Norway were also included in afflicted propositi studied. Duration of overt disease was estimated from the date of first recorded clinical symptoms and ranged from 1 to 28 yr. 115 blood samples from members of 31 families of HD patients were also studied. First-degree relatives were defined as parents, children, and siblings of probands with HD whereas second-degree relatives were twice removed from the proband (i.e., grandparents, uncles, aunts, cousins, nieces, and nephews). An attempt was made to study as many living relatives, both blood related and nonblood related, as were available. In addition, whenever possible, particular care was used to study spouses of patients afflicted with HD. In all, a total of 20 spouses were included in this phase of the study.

In one HD patient, simultaneous serum and cerebrospinal fluid samples were available. Spinal fluid was concentrated 50 times to obtain an IgG concentration similar to that of the serum (11.0 mg/ml).

Control sera were drawn from a group of normal subjects and patients with diverse medical conditions as previously noted (9). An additional new group of 198 neurological controls was included in the present study. These were obtained from the in-patient and out-patient neurology services of the Bernalillo County Medical Center, Albuquerque Veterans Administration Hospital, and St. Josephs Hospital, Albuquerque, N. Mex. Sera were obtained from patients with a wide variety of neurological diseases including Parkinson's disease, senile dementia, transverse myelitis, strokes, brain and spinal cord tumors, central nervous system trauma, multiple sclerosis, and miscellaneous neurological conditions. A summary of the types of patients included among the neurological controls is shown in Table I.

Assay systems. The primary study technique utilized indirect immunofluorescence and unfixed frozen sections of normal adult human brain as previously described (8, 9). Brain was obtained from the medical examiner's office from individuals who had sustained accidental death and was studied within 4–12 h of death. Small 2 × 2 × 5-mm blocks were obtained from caudate and subthalamic areas as well as cerebral cortex, cerebellum, geniculate ganglion, and spinal cord, the latter to include large anterior horn cells in cross

TABLE I
Prevalence of Antineuronal Antibody in HD
and Various Control Groups

	Mean age	No. subjects tested	No. positive
	<i>yr</i>		
HD	60	80	37(46%)*
Neurological disease controls			
Degenerative/vascular disease: senile dementia, cerebral infarction, cerebral hemorrhage, multiple cerebrovascular accidents	65	65	5
Primary brain tumors: meningioma, medulloblastoma, astrocytoma, glioma, glioblastoma, pituitary adenoma sarcoma	53	14	1
CNS trauma: depressed skull fracture, subdural hematoma, epidural hemorrhage, quadriplegia, gunshot wounds	39	25	1
Miscellaneous neurological conditions: seizures, amyotrophic lateral sclerosis, myasthenia, transverse myelitis, peripheral neuritis, vestibular neuritis, Tic douloureux, spinocerebellar degeneration	38	31	2
		30	1
		165	10 (6%)
Parkinson's disease	69.0	33	11 (33.3%)
Miscellaneous disease controls: pneumonia, chronic liver disease, cancer, arteriosclerotic heart disease, lymphoma, emphysema, peptic ulcer, inflammatory bowel disease	56	70	3*
Normal controls	30	60	2*

* Difference between prevalence of antibody in HD and normals by chi square, $P < 0.0005$ and difference between HD and miscellaneous disease controls, $P < 0.0005$.

section. Before frozen sections were prepared, brain samples were carefully washed at 4°C for 2–24 h in cold phosphate-buffered saline (PBS) in an effort to remove adsorbed blood or plasma proteins.

4–6- μ m frozen sections were cut in a cryostat and used unfixed on slides. Indirect immunofluorescence proce-

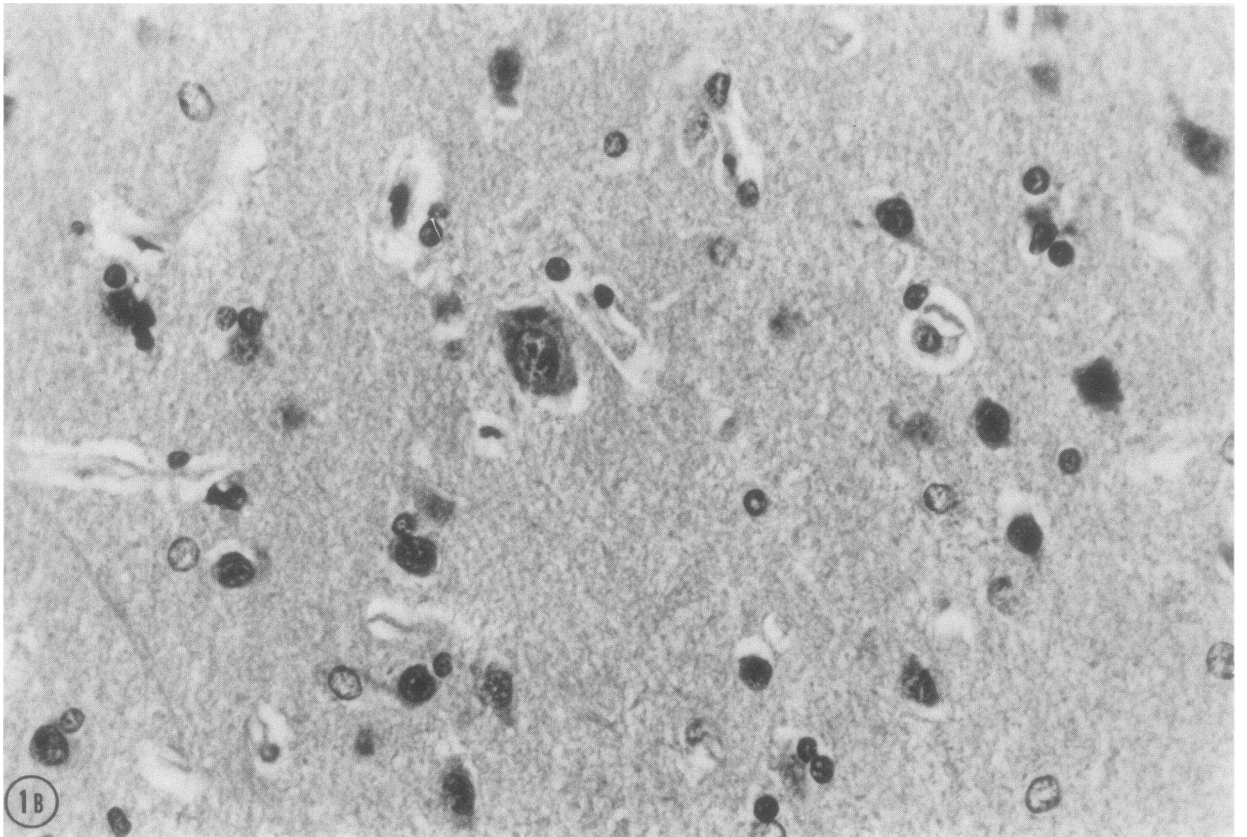
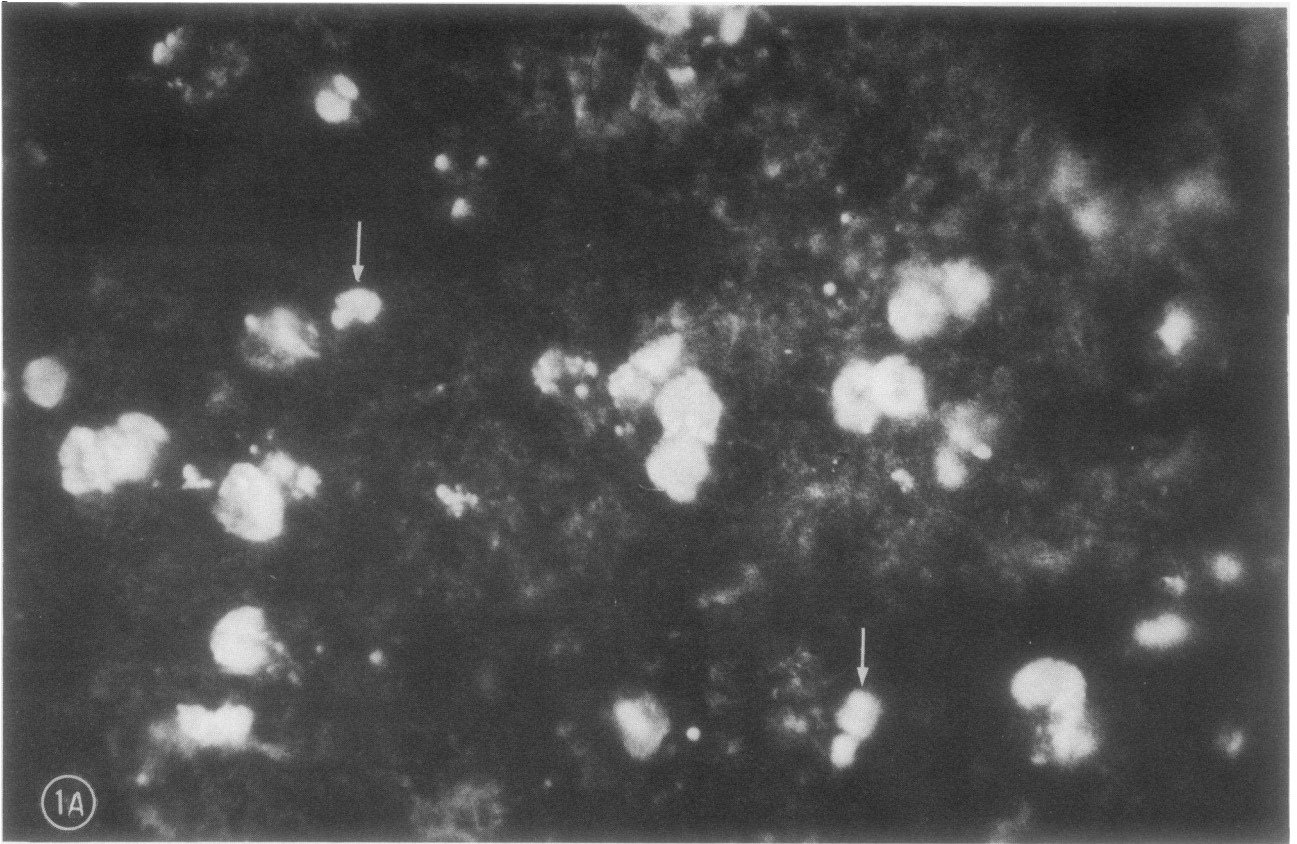

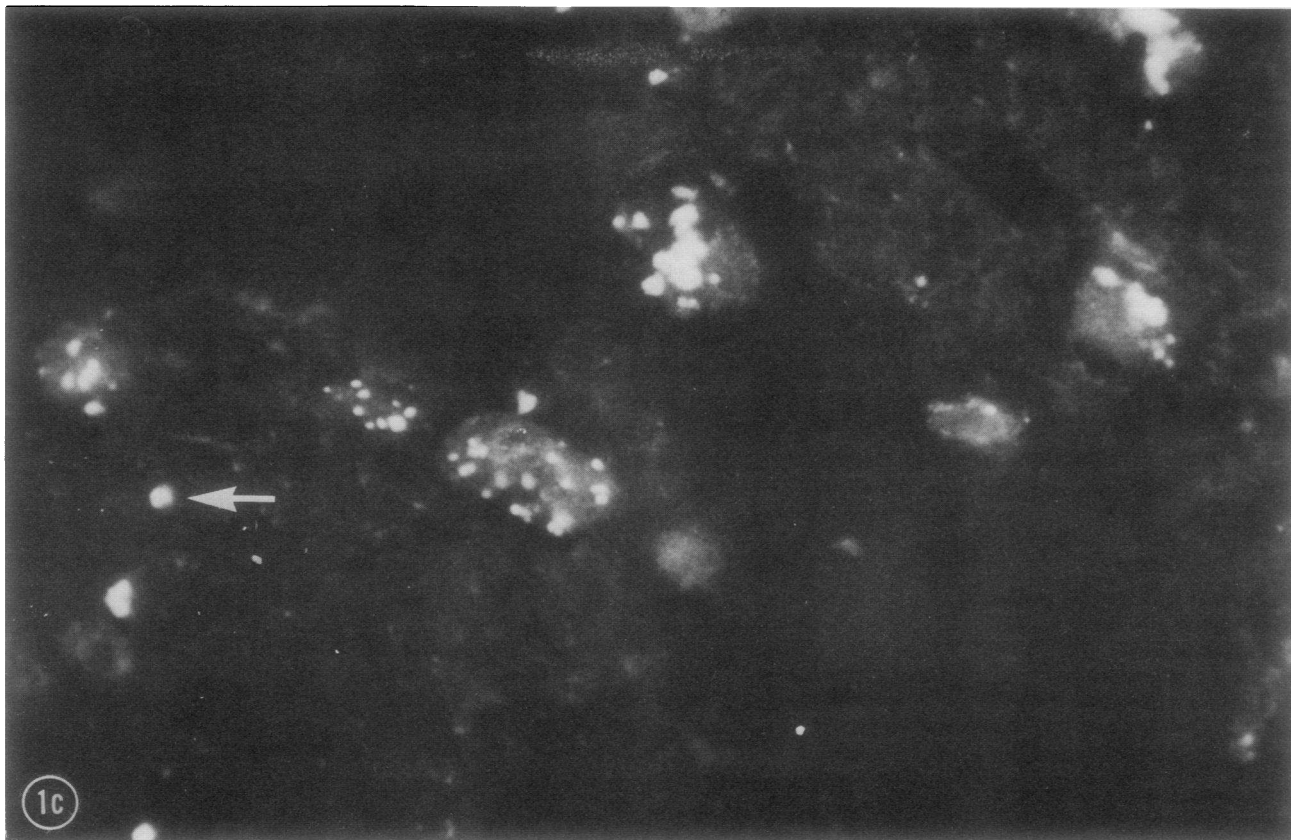

FIGURE 1C Immunofluorescence reactions of antineuronal antibody again showing light green specific fluorescence of entire neuronal cytoplasm. Bright orange-yellow autofluorescent lipofuscin granules (arrow) are noted within cells ($\times 500$).

dures followed those previously outlined (9, 10). Briefly, after incubation of tissue sections for 30 min with undiluted test and control sera (heat inactivated at 56°C for 30 min), sections were washed twice for 10 min in PBS, and fluorescein-conjugated rabbit anti-human IgG, IgA, or IgM was applied with subsequent incubation and washing in PBS. Specificity of fluorescent staining was checked by standard blocking and absorption procedures (9). Sections were also examined with fluoresceinated reagents alone without application of test sera. Most sections were read blind by two observers (G. H. and K. K.) and concordant positive and negative results were recorded. To examine species specificity of the antineuronal antibodies, brain samples from rats were also obtained and were used in indirect immunofluorescence tests as described for the human brain samples. Rat brains were perfused with 60 ml of cold PBS before removal.

Previous studies by Aarli et al. (11) have indicated that some nonspecific reactions between IgG and central

nervous system tissues may be due to Fc binding of IgG to myelin components. Accordingly, IgG from positive sera was isolated by ammonium sulfate precipitation or DEAE ion-exchange chromatography and pepsin digested to produce $\text{F}(\text{ab}')_2$ fragments as previously described (9). Specificity of IgG binding to central nervous system structures was thus studied by comparing immunofluorescence with whole serum or isolated IgG and $\text{F}(\text{ab}')_2$ fragments of the same IgG.

To examine the ability of the antineuronal antibodies to bind complement, sections were incubated with positive sera and washed as described, thereafter overlaid with fresh normal human serum as a source of complement, washed, and finally treated with fluorescein isothiocyanate-labeled antihuman C3. As a control, the normal human serum was heat inactivated at 56°C for 30 min before use.

A search for specificity of antineuronal fluorescent staining was made using various types of enzymatic and clinical treatments of frozen sections with modifications of

FIGURES 1A and B (A) Immunofluorescence photomicrograph of positive staining patterns showing antineuronal antibody. Staining of caudate nucleus cytoplasmic structures was clearly seen with apparent relative sparing of nuclei. Bright dots (arrows) represented orange-yellow autofluorescence of lipofuscin granules within individual neurons. Diffuse light green specific fluorescence was seen in medium and larger neurons (magnification $\times 460$). (B) Parallel section of human caudate nucleus to that shown in (A) stained with hematoxylin and eosin. This area is populated by nerve cell bodies of large and intermediate size ($\times 460$).

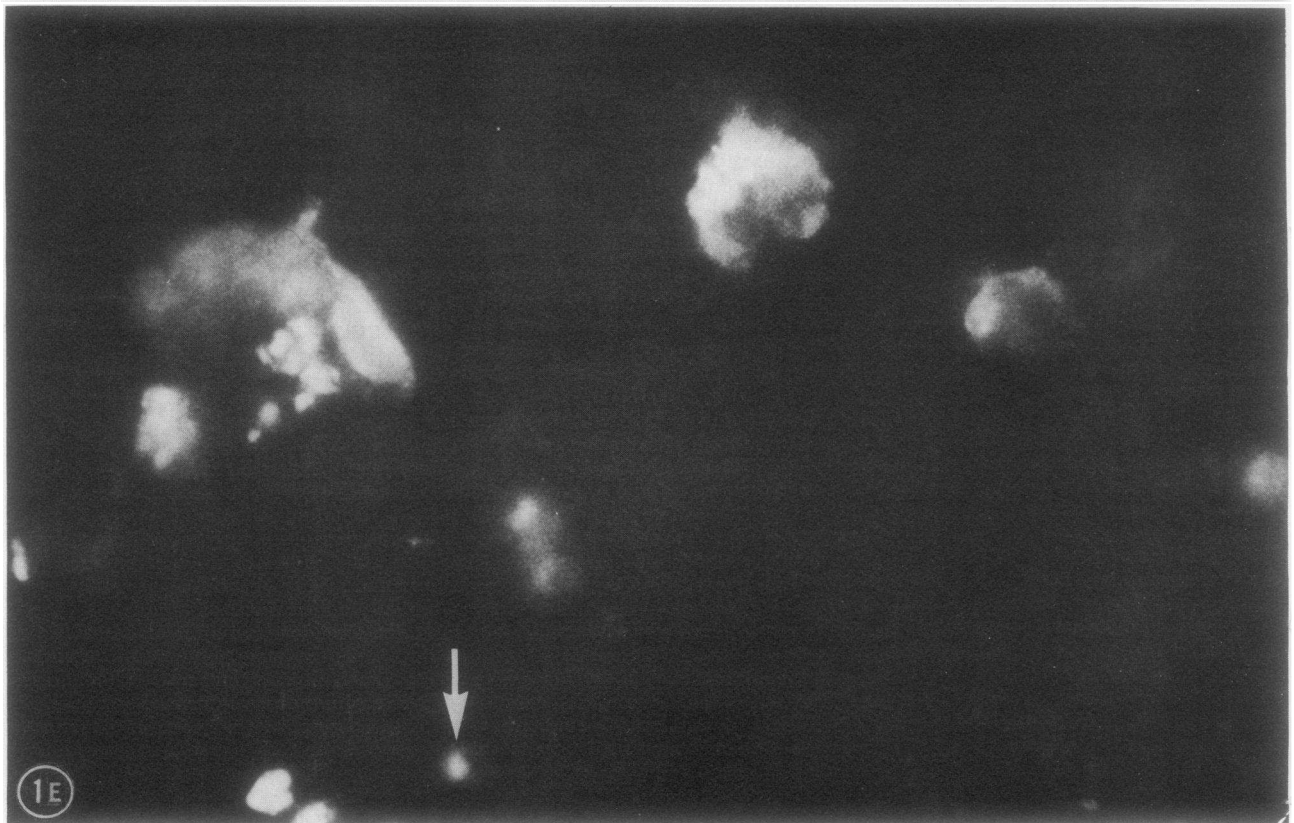
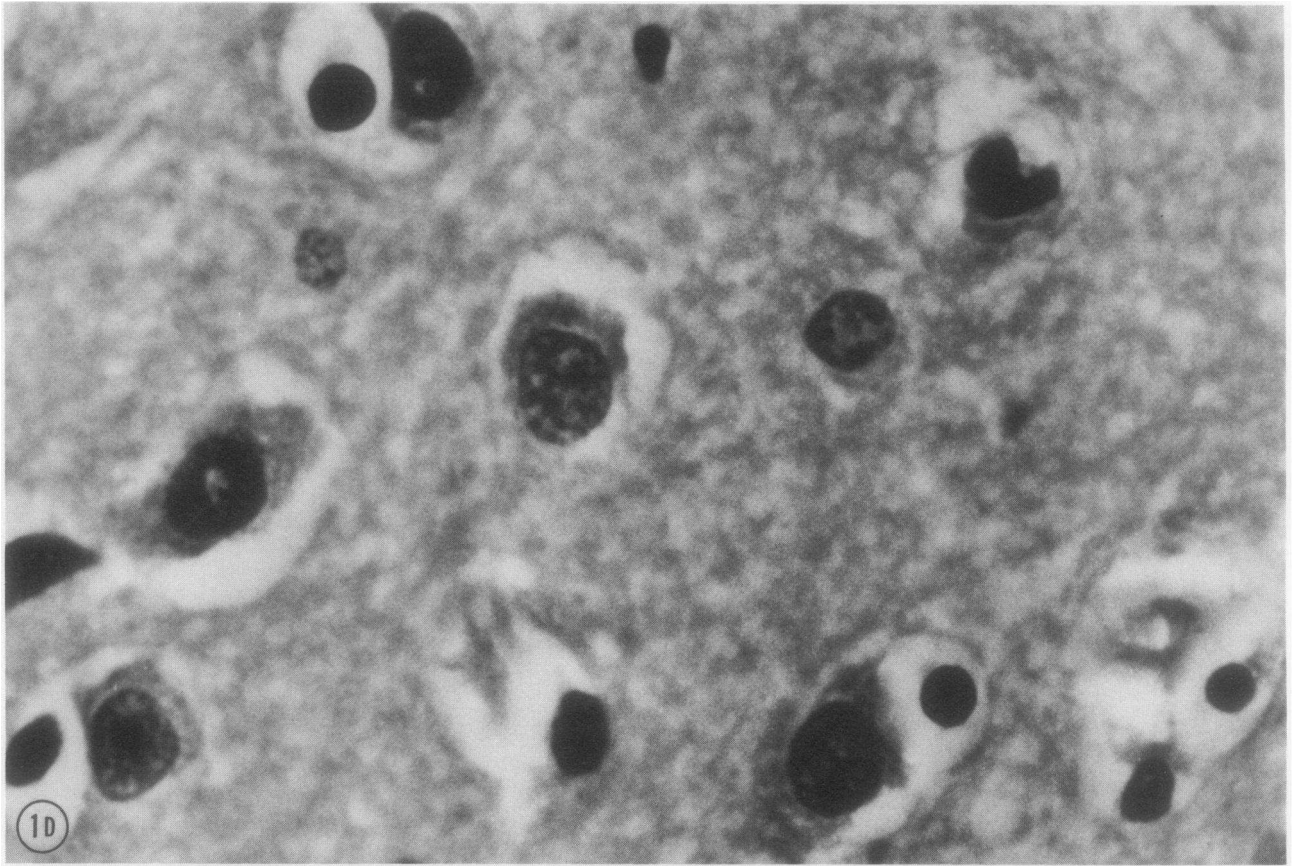

several methods previously described (12–15). Frozen sections were treated with trypsin, periodate, EDTA, sulfhydryl-active agents, DNAase, RNAase, neuraminidase, and lipase. Trypsin (Worthington Biochemical Corp., Freehold, N. J.) digestion utilized concentrations of 0.001 mg/ml trypsin in Tris buffer, at pH 8.6, for 60 min at 37°C. After trypsin digestion, 30 µg soya bean trypsin inhibitor was applied for 10 min to stop trypsin reactivity, followed by three 4-min washes in PBS, pH 7.4. In some experiments, dithiothreitol was used in conjunction with trypsin (14). 2 mM dithiothreitol was buffered to pH 8.6 with Tris buffer, and enzymatic digestion was carried out in the presence of the reducing agent. Neuraminidase (VCN) (Calbiochem, San Diego, Calif.) was used at concentrations of 15, 25, 50, 125, and 250 U/ml. VCN treatment was carried out at 37°C in acetate buffer, at pH 5.1, for 30 min followed by a brief 15-s wash and three 4-min washes of sections in PBS. In addition, a combination of VCN and 64 mM EDTA treatment at 37°C, pH 5.0, for 30 min was also utilized in some experiments. VCN was applied and washed off the sections as described, followed by incubation at room temperature in EDTA for 30 min. After three 4-min washes in PBS, slides were overlaid with test serum and fluorescence procedure was followed. This treatment was specifically selected since previous reports by Woolley and Gommi (13) showed destruction of serotonin receptors by VCN plus EDTA but not by either reagent when used alone. Periodate treatment of tissue sections was performed for 30 min at 22°C with concentrations of 64, 16, 4, 1, 0.25, and 0.06 mM using methods described by Matre et al. (15). DNAase (Worthington Biochemical Corp.) treatment of tissue sections used 0.005 mg/ml, pH 7.0, for 1 h at 37°C and RNAase (Worthington) employed 4 µg/ml of enzyme on sections, at pH 7.4, for 1 h at 37°C. Lipase (*Rhisopus delemar* 6,000 U/mg, Miles Laboratories, Inc., Research Div., Kankakee, Ill.) was applied at concentrations of 1,200, 600, 300, 150, and 30 U/ml in conjunction with 0.1 M phosphate buffer, pH 5.8. After 52 min of incubation at 22°C, tissue sections were washed three times in PBS for 4 min. For all enzymes or chemical treatments, two types of controls were used. Sections treated with PBS or base-line buffers instead of enzymes or reagents served to test for the effects of these reagents alone. Also enzyme-treated sections were overlaid with normal human serum to monitor specificity of subsequent immunofluorescence reactions.

Preparations rich in isolated neurons were obtained from human caudate nucleus using the technique of Selinger et al. (16). These preparations were also used for absorption studies (9). Lyophilized proteins extracted from whole caudate nucleus with perchloroacetic acid using the method previously described by Wedege (17) were also used for absorption of six selected sera at a concentration of 10 mg/ml.

In some instances sera from HD patients showing strong immunofluorescent staining of human caudate nuclear neuronal cytoplasm were tested for possible specificity for group A streptococcal antigens utilizing group A membranes, cell walls, and carbohydrate kindly provided by Doctors I. van de Rijn and J. Zabriskie, The Rockefeller University, New York, and prepared as previously described (9).

TABLE II
Antibody Titration and Complement Fixation Tests of
Positive Antineuronal Antibody Sera from
Patients with HD

Antibody titration*		Complement fixation*
Titer	No. of patients	No. positive/no. tested
Neat	11	8/10
1:2	5	2/4
1:4	8	5/6
1:8	8	4/8
1:16	4	2/3
1:32	0	—
NTxx	1	—
Total	37	21/31

* Determined by indirect immunofluorescence on frozen sections from human caudate nucleus. xx not titrated.

To check for possible presence of antinuclear antibodies, mitochondrial antibodies, and microsomal antibodies, sera were tested by indirect immunofluorescence technique using unfixed frozen sections from rat and human liver as substrate for nuclei, and human kidney as substrate for the two cytoplasmic antigens (10, 18, 19). In these assays the sera were screened undiluted.

RESULTS

HD subjects. 37 of the 80 sera (46.3%) from HD subjects studied showed positive staining reactions for neuronal cytoplasmic fluorescence (Table I, Fig. 1). The titers of positive sera are shown in Table II. The neuronal cytoplasmic staining was much more prominent with medium-sized neurons found in the caudate nucleus, subthalamic, and basal ganglia areas than with neurons of other comparable regions such as cerebral cortex, cerebellum, geniculate ganglion, amygdala, or anterior horn cell areas of spinal cord. It was clear that neither cerebellar Purkinje cells nor large motor anterior horn cell neurons of spinal cord were stained by any of the positive sera. Thus, the most prominent fluorescent staining for antineuronal antibody consistently occurred with sections of caudate nucleus or subthalamic areas. Comparative results using sections of human caudate nucleus, cerebral cortex, and trigeminal nucleus are shown in Table III.

Almost identical immunofluorescent findings were observed when corresponding brain samples from rats were used instead of human material providing

FIGURES 1D and E (D) Parallel hematoxylin and eosin section (to C) of human caudate nucleus showing types of large and intermediate neuronal bodies involved in specific immunofluorescence (×500). (E) Immunofluorescence of human caudate nucleus neurons again showing diffuse cytoplasmic apple green fluorescence which spares nuclear structures. Arrow shows lipofuscin autofluorescent granules (×520).

TABLE III
Comparative Staining Reactions Using Sera from 10 Patients
with Huntington's Chorea and Frozen Sections of
Normal Human Brain

Patient no.	Caudate nucleus	Cerebral cortex	Trigeminal nucleus
1	+++ (1:8)‡	++ (1:2)‡	++ (1:2)
2	++ (1:4)	++ (1:2)	++ (1:2)
3	0	0	0
4	++ (1:2)	±	±
5	++ (1:4)	++ (1:1)	++ (1:1)
6	++ (1:1)	±	±
7	0	0	0
8	0	0	0
9	0	0	0
10	0	0	0

* Relative strength of immunofluorescence with undiluted serum.

‡ Figures in parentheses refer to titer of positive staining in immunofluorescence.

evidence that the antineuronal antibodies were not species specific.

Concomitant screening of test sera for the presence of antinuclear antibody as well as mitochondrial and microsomal antibodies was performed to insure neuronal cytoplasmic specificity of the immunofluorescent staining. Five of the positive sera from HD patients showed antinuclear reactivity. However, in these five sera, immunofluorescent staining was also localized to neuronal cytoplasmic structures clearly identified by the concomitant finding of autofluorescent granules of lipofuscin known to be present in the cyto-

plasm of such cells (Fig. 1). None of the sera was shown to contain antimitochondrial or antimicrosomal reactivity when tested on rat and human kidney sections.

An attempt was next made to examine whether the presence of positive reactions for antineuronal antibody correlated in any way with clinical duration of disease. Two patients included as presumptive HD had not as yet manifested clinical symptoms but had one parent and one child already involved with overt HD. These subjects (both negative for antineuronal antibody) were not included in this analysis. In 74 patients, where accurate clinical data were available about actual initial onset of disease, it appeared that a larger proportion of patients with duration of disease greater than 7 yr (21/36) showed positive antibody reactions than did subjects with disease duration of 7 yr or less (16/38) (chi-square, 2.82). However, some exceptions to these data were observed. These data are shown graphically in Fig. 2. It can be seen that sera showing higher titers of antineuronal antibody were more prominent in patients with disease duration of over 7 yr. If patients with titer of antibody of 1:2 or greater in subjects with less than 7 yr of clinical disease were compared to those with 7 yr duration or greater, chi-square was 9.06 ($P < 0.001$).

In one patient where both serum and spinal fluid were available, concentrated spinal fluid showed only a weak (\pm) and immunofluorescence reaction whereas serum produced stronger staining (2+) and was positive to a dilution of 1:16.

A diverse group of control patients was also examined

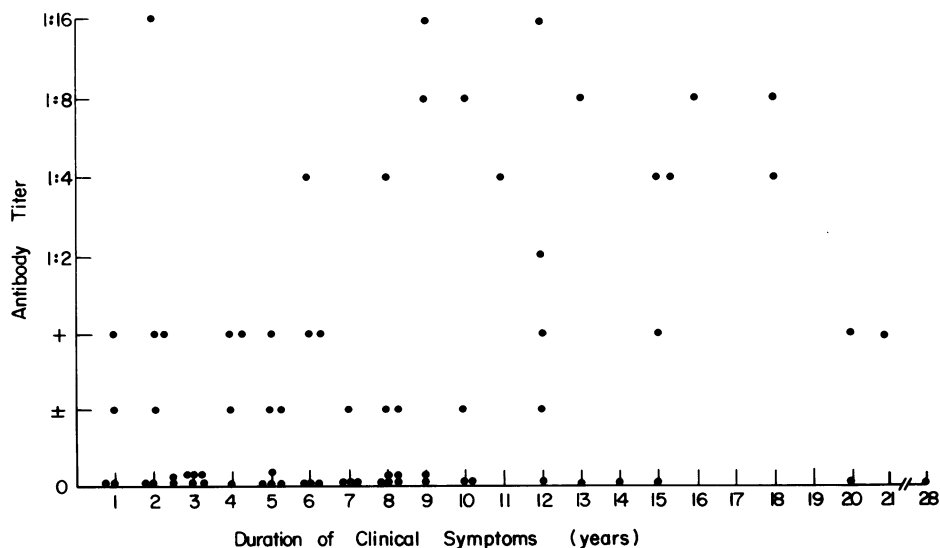

FIGURE 2 Graph showing relationship between presence and titer of antineuronal antibody and duration in years of clinical manifestations of HD in 74 patients.

for the presence of antineuronal antibody. Results are summarized in Table I. It can be seen that a low overall incidence of antineuronal antibody was noted among normal subjects (3.3%) and control patients with various miscellaneous medical disorders (4.2%). A slightly higher general prevalence (6%) of antineuronal antibody was recorded in the neurological control group. Of particular interest was the presence of the antibody in one-third of 33 patients with Parkinson's disease, with titers comparable to those of HD patients (Table II). Patients with intracranial tumors, strokes, or miscellaneous neurological conditions showed a lower overall prevalence of positive reactions for antineuronal antibody.

Assay for complement binding. Sections sequentially incubated with positive HD sera, fresh normal human serum, and fluorescein isothiocyanate-labeled anti-C3 showed cytoplasmic staining similar to that of the antineuronal antibodies in 22 of the 31 sera tested. There was apparently no correlation between the antineuronal antibody titer and the capacity for complement fixation (Table II). When the fresh human serum was heat inactivated in control experiments, no fluorescent staining was observed. These experiments clearly demonstrated that antineuronal antibodies present in HD sera were capable of complement fixation. In contrast, none of the eight positive sera tested from patients with Parkinson's disease showed complement fixation when indirect immunofluorescence technique was used.

HD family studies. 115 sera from 31 families containing at least one HD proband were studied for presence of antineuronal antibody. These sera included 20 husband-wife spouse pairs in which one (husband or wife) had established HD. 6 of 20 unaffected spouses (30%) of subjects with HD showed presence of positive reactions for antineuronal antibody. One spouse showed a titer of 1:16 which was among the highest recorded. Her HD-affected husband was also positive with 1:4 titer. In addition, 13 of 56 first-degree HD family members (23.2%) clearly at risk for eventual development of HD (children of marriages where one parent had established HD) showed presence of antineuronal antibody. By contrast, only 10.5% or 2 of 19 nonblood-related relatives where such family members were married to spouses at risk for HD were positive for antineuronal antibody. In addition, 19 second-degree relatives indirectly at risk for HD (grandparents with HD) showed a 10.5% incidence of antibody. Analysis of these data by the chi-square method showed a highly significant difference between spouses and first degree relatives directly at risk and normal controls ($P < 0.001$), Table IV. Illustrative examples of representative family distribution of antineuronal antibody are shown in Fig. 3.

Attempts to characterize HD serum-staining anti-

TABLE IV
Prevalence of Antineuronal Antibody in HD Families

Family members tested	No. tested	No. positive
Proband with HD	80	37
Spouses of probands with HD	20	6*
First-degree HD relatives	56	13‡
Second-degree HD relatives	19	2§
Nonblood related relatives (excluding spouses)	19	2
Normal controls	60	2*‡§

* Difference between prevalence of antibody in normal controls and spouses of HD probands, $P < 0.001$.

‡ Difference between normal controls and first-degree relatives by chi square, $P < 0.001$.

§ Chi square difference between normals and second-degree relatives NS.

gen. Frozen tissue sections were treated with DNAase and RNAase and examined with a panel of strongly positive sera. DNAase digestion of sections produced no change in staining, however slight diminution was recorded after RNAase digestion in several instances. Trypsin digestion was also associated with diminution in positive staining of neuronal cytoplasm. No significant changes in staining patterns were noted after lipase, VCN, or EDTA after lipase, neuraminidase, or EDTA treatment. Some increase in immunofluorescent staining occurred after periodate treatment; however this appeared to be nonspecific since parallel control observations using previously negative normal sera also showed an increased general tendency for binding to periodate-treated sections. Similar results using this reagent have been previously recorded (12).

Studies of specificity. 31 of the 37 HD sera positive for antineuronal antibodies were also tested using fluorescein isothiocyanate-labeled rabbit antibodies specific for IgG, IgM, and IgA, respectively. In all cases only antineuronal antibodies of the IgG class were detected.

Binding of HD IgG antibody to neuronal tissues was assessed before and after IgG digestion by pepsin. Serum and isolated IgG from positive sera were studied in parallel with pepsin F(ab')₂ fragments of IgG in immunofluorescence reactions. Clear evidence of antibody combining-site binding using F(ab')₂ fragments as well as whole IgG preparations was obtained in all positive sera tested (Table V).

In addition, careful absorption of HD sera with group A streptococcal cell walls, membranes, and purified carbohydrate, utilizing methods previously described (9), produced no diminution or significant

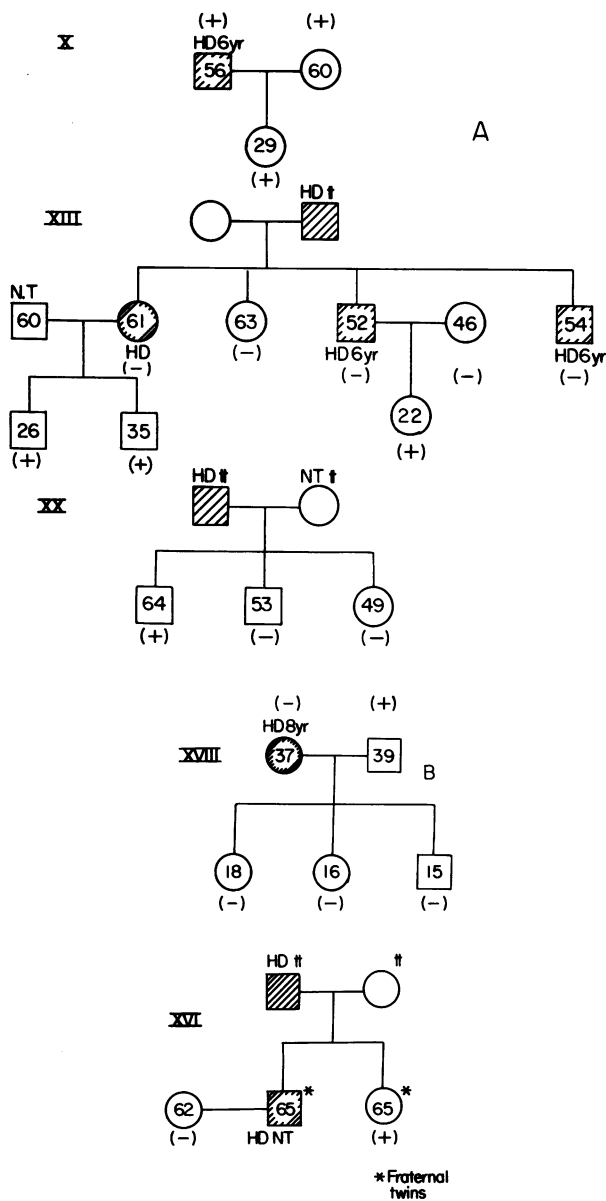

FIGURE 3 Diagrams of representative familial constellations of HD and the occurrence of antineuronal antibody. Designations in parentheses (+) or (0) indicate positive or negative tests for antineuronal antibody. Ages of family members are shown by numbers inside circles or squares. (A) Family X shows positive tests in nonblood-related spouse of proband as well as in as yet unaffected daughter aged 29. Family XIII shows three affected siblings with HD all negative for antibody, however positive tests in three as yet nonaffected children ages 26, 35, and 22. Family XX shows positive antibody in a 65-yr-old as yet nonaffected son with negative tests in his two siblings. (B) Family XVIII shows a negative serum antibody test in the 37-yr-old affected proband with positive tests in her husband and negative tests in the three as yet nonaffected children. Family XVI shows a family containing fraternal twins. The affected male twin was not available for testing but the female as yet nonaffected twin was positive for antineuronal antibody.

abolition of positive staining. The absence of absorption by group A streptococcal antigens clearly differentiated the antineuronal antibody of HD from that associated with rheumatic fever and Sydenham's chorea (9). Preparations of isolated caudate nucleus neurons obtained by the Selinger technique (16) were used for absorption in conjunction with isolated human hepatocytes or extracts of human liver and kidney. Clear absorption of antineuronal antibody was accomplished by preparations of isolated neurons. Furthermore, absorption of positive HD sera with perchloroacetic acid extracts from normal human caudate nucleus (17) containing extractable cytoplasmic proteins also completely removed immunofluorescent staining.

DISCUSSION

This study demonstrates the presence of serum IgG antibodies reacting with antigens localized in neuronal cytoplasm in 46% of 80 patients afflicted with HD. Although neurons showing reactivity were also present in other areas of the central nervous system, strong concentration of the antigen appeared to be present in subthalamic and caudate nucleus areas of normal brain. Antineuronal antibodies in HD sera apparently showed different specificity from those previously described in the sera of children with rheumatic fever and Sydenham's chorea (8, 9) since they were not absorbed with group A hemolytic streptococcal membranes. Absorption of antibody was, however, complete using isolated neuronal preparations. The antigen in neuronal cytoplasm reacting with HD antineuronal antibodies has not yet been fully characterized but appears to be relatively resistant to digestion with VCN, lipase, DNAase, and treatment with EDTA. Definite reduction in positive staining patterns was recorded after trypsin digestion of frozen sections or after RNAase treatment. The effective absorption of antineuronal antibodies with perchloroacetic acid extracts from normal caudate nucleus indicates that the antigen(s) involved belong to the group of proteins extractable with this reagent (17). Further characterization of subcellular neuronal cytoplasmic fractions eventually employing immunological electron microscope techniques will be necessary before the exact cellular localization of the neuronal HD-reactive antigen is clear.

Spinal cord anterior horn motor neurons and cerebellar Purkinje cells were not stained and neurons in the amygdala and locus ceruleus also showed negative or very weak staining. Absence of staining of Purkinje cells which possess gamma aminobutyric acid receptors was of particular interest.

Antineuronal antibodies in HD subjects appeared to show some relation to previous duration of clinical

cal disease in that the prevalence of antibody as well as mean titer was higher in subjects with clinical disease manifestations over 7 yr. The serum antibody detected in these studies was restricted to the IgG class. Unfortunately only one sample of cerebrospinal fluid has been available for study. Since 46% of 80 HD subjects studied showed antibody, it is conceivable that a different spectrum or prevalence of antibody might be present in spinal fluid if the primary genesis of antibody production were in the central nervous system itself. Such a situation has been amply demonstrated in the case of subacute sclerosing panencephalitis where oligoclonal restriction of cerebrospinal fluid antibody to measles-like antigens has been demonstrated (20). The prevalence of antibody reacting with neuronal antigens was relatively low among miscellaneous neurological controls including those with demyelinating disorders, a variety of strokes, brain tumors, or previous trauma to central nervous system. A striking exception to this was recorded among patients with Parkinson's disease where the incidence of positive tests for antibody was 33.3%. The high proportion of positive antineuronal antibody reactions among subjects with Parkinson's disease may represent a fascinating parallel finding to the current study of HD. Both disorders represent physiological disturbance of neuronal function in basal ganglia structures. Indeed HD can be present in a rigid form clinically suggesting Parkinson's disease (21, 22). In both, damage to neurons and subsequent alteration of native autologous neuronal antigens might be capable of inducing synthesis of antibodies directed against damaged neuronal structures. The increased titer and prevalence with duration of disease in HD might indeed fit with such an hypothesis. However, it is conceivable that antineuronal antibody in both conditions might be directed against virally induced antigens somehow associated with expression of the disease. Postinfluenzal Parkinsonism has in the past been attributed to long-term viral sequelae and it still remains a possibility in terms of the etiology of the whole disease spectrum itself (23, 24).

The species nonspecific nature of the antineuronal antibodies provides interesting possibilities for the development of an experimental model of HD in animals, however it is difficult to understand how the antibody during life could directly react with cytoplasmic antigen localized within individual neurons.

The demonstrated ability of the antineuronal antibodies to fix complement, along with binding of pepsin F(ab')₂ antibody fragments, provides further support for the antibody nature of this reaction. Whether or not this is involved directly in pathogenesis or in the tissue lesions themselves must await direct

TABLE V
Comparative Antineuronal Antibody Reactions Using Whole Serum, IgG, and F(ab')₂ Fragments from Representative HD Samples

Patient serum studied	Whole serum	IgG	F(ab') ₂
Male, 50 yr	1:8*	1:4	1:4
Female, 56 yr	1:4	1:4	1:4
Male, 58 yr	1:16	1:16	1:8

* Titer of antineuronal antibody staining by indirect immunofluorescence.

parallel studies of the lesions themselves in HD cerebral tissues.

Several previous reports have documented the presence of antineuronal antibodies in sera from patients with carcinomatous neuropathy (23-27). It is not clear what relationship these reactions have to the antineuronal antibodies documented in the present report.

The family studies recorded here provide fascinating preliminary data which appear to link an environmental influence or conceivably an infectious agent to the expression of HD. Most telling in this regard were the studies of the 20 spouse pairs where 30% of unaffected spouses showed presence of antineuronal antibody. First-degree relatives directly at risk showed a prevalence of 23% as against the prevalence of 3% in normal controls. As degree of direct relation to HD parent or grandparents declined, the prevalence of positive antineuronal antibody fell to 10.5%. Since HD has been previously clearly shown to be related to an autosomal dominant inheritance pattern, these data considered together suggest that antineuronal antibody may reflect exposure to some agent or common environmental factor. Such exposure, if it were a virus or slow viral infection (28, 29), might be magnified in spouses of afflicted patients. However, to actually develop clinical manifestations and progression of the disease, one would theoretically have to possess a specific HD-reactive IR gene (30, 31). Such a hypothesis might explain the findings recorded in the current report. Additional studies are now needed to attempt to characterize the antigen reactive with HD antineuronal antibody and to further explore the prevalence of such antibody in kindreds as well as spouses of patients with Parkinson's disease.

ACKNOWLEDGMENTS

The authors are indebted to the many physicians who assisted in providing serum samples from their patients with Huntington's disease. In particular, Dr. William J. Kimberling, Denver, Colo., Dr. Ruth Atkinson, Albuquerque, New Mex., Dr. Charles Terry, Waco, Tex., Dr. Elmo Anderson, Al-

buquerque, New Mex., Dr. John Hester, Fort Lions, Colo. Dr. L. J. Barber, Roswell, New Mex., Dr. William Rosenzweig, Tulsa, Okla., Dr. O. Devarajan, Newton, Conn., Dr. J. Vaughan, Las Vegas, New Mex., Dr. E. Sagedal of Eeg Hospital, Kristiansand, Norway, and Dr. B. Bandvik, Oslo, Norway were of great help in collecting serum samples from HD patients. It is also a pleasure to acknowledge the superb technical help of Ms. Kathy Kilpatrick and the expert secretarial assistance of Ms. Bernadette Marquez. We are also indebted to Dr. Mario Kornfeld for help with neuropathological dissections and photomicrographs of neural tissue and Dr. Betty Skipper for advice with statistical analysis.

This research was supported in part by grants 13824-07 and T01A10053 from the U. S. Public Health Service and in part by a grant from the Kroc Foundation.

REFERENCES

- Huntington, G. 1872. On chorea. *Med. Surg. Rep. Philad.* **26**: 317-321.
- Dunlap, C. B. 1927. Pathologic changes in Huntington's chorea with special reference to the corpus striatum. *Arch. Neurol. Psychiatr.* **18**: 867-943.
- Blinderman, E. E., W. Weidner, and C. H. Markham. 1964. The pneumoencephalogram in Huntington's chorea. *Neurology.* **14**: 601-607.
- Tellez-Nagel, I., A. B. Johnson, and R. D. Terry. 1974. Studies on brain biopsies of patients with Huntington's chorea. *J. Neuropathol. Exp. Neurol.* **33**: 308-332.
- Myrianthopoulos, N. C. 1966. Huntington's chorea. *J. Med. Genet.* **3**: 298-314.
- Bird, E. D., A. V. P. MacKay, C. N. Rayner, and L. L. Iversen. 1973. Reduced glutamic-acid-decarboxylase activity of post-mortem brain in Huntington's chorea. *Lancet.* **I**: 1090-1092.
- Perry, T. L., S. Hansen, and M. Kloster. 1973. Huntington's chorea. Deficiency of γ -aminobutyric acid in brain. *N. Engl. J. Med.* **288**: 337-342.
- Husby, G., J. B. Zabriskie, Z. H. Abdin, and R. C. Williams, Jr. 1976. Antibodies reacting with cytoplasm of subthalamic and caudate nuclei neurons in chorea and acute rheumatic fever. *Clin. Res.* **24**: 447. (Abstr.)
- Husby, G., I. van de Rijn, J. B. Zabriskie, Z. H. Abdin, and R. C. Williams, Jr. 1976. Antibodies reacting with cytoplasm of subthalamic and caudate nuclei neurons in chorea and acute rheumatic fever. *J. Exp. Med.* **144**: 1094-1110.
- Husby, G., J. P. Blomhoff, S. Skrede, K. Elgjo, and E. Gjone. 1973. Detection of immunoglobulins in paraffin-embedded liver biopsies. Studies in 100 patients with special regard to immunological findings in active chronic hepatitis. *Scand. J. Gastroenterol.* **8**: 621-629.
- Aarli, J. A., S. R. Aparicio, C. E. Lumsden, and T. Tönder. 1975. Binding of normal human IgG to myelin sheaths, glia and neurons. *Immunology.* **28**: 171-185.
- Lachmann, P. J., and H. G. Kunkel. 1961. Correlation of antinuclear antibodies and nuclear staining patterns. *Lancet.* **II**: 436-437.
- Woolley, D. W., and B. W. Gommi. 1964. Serotonin receptors: V. Selective destruction by neuraminidase plus EDTA and reactivation with tissue lipids. *Nature (Lond.)* **202**: 1074-1075.
- Kolk, A. H. J., T. Samuel, and P. Rümke. 1974. Auto-antigens of human spermatozoa. I. Solubilization of a new auto-antigen detected on swollen spermheads. *Clin. Exp. Immunol.* **16**: 63-76.
- Matre, R., O. Tönder, S. Thunold, and J. H. Solhaug. 1976. Properties of Fc γ receptors in normal and malignant human tissues. *Scand. J. Immunol.* **5**: 361-368.
- Selinger, O. Z., J. M. Azcurra, D. E. Johnson, W. G. Ohlsson, and Z. Lodin. 1971. Independence of protein synthesis and drug uptake in nerve cell bodies and glial cells isolated by a new technique. *Nat. New Biol.* **230**: 253-256.
- Wedegge, E. 1973. Isolation of an acid-soluble basic protein from monkey brain. *J. Neurochem.* **21**: 1487-1497.
- Doniach, D., and G. Walker. 1972. Immunopathology of liver disease. In *Progress in Liver Diseases*. H. Popper and F. Schaffner, editors. Grune & Stratton, Inc., New York. 381-402.
- Rizzetto, M., G. Swana, and D. Doniach. 1973. Microsomal antibodies in active chronic hepatitis and other disorders. *Clin. Exp. Immunol.* **15**: 331-344.
- Vandvik, B., and E. Norrby. 1973. Oligoclonal IgG antibody response in the central nervous system to different measles virus antigens in subacute sclerosing panencephalitis. *Proc. Natl. Acad. Sci. U. S. A.* **70**: 1060-1063.
- Campbell, A. M. G., B. Corner, R. M. Norman, and H. Ulrich. 1961. The rigid form of Huntington's disease. *J. Neurol. Neurosurg. Psychiatry.* **24**: 71-77.
- Bird, M. T., and G. W. Paulson. 1971. The rigid form of Huntington's chorea. *Neurology.* **21**: 271-276.
- Duvoisin, R. C., and M. D. Yahr. 1965. Encephalitis and parkinsonism. *Arch. Neurol. Chicago.* **12**: 227-239.
- Field, W. S. (Ed.) 1958. *Pathogenesis and Treatment of Parkinsonism*. Charles C. Thomas, Publisher. Springfield, Illinois.
- Wilkinson, P. C., and J. Zeromski. 1965. Immunofluorescent detection of antibodies against neurones in sensory carcinomatous neuropathy. *Brain.* **88**: 529-538 (and plates LVIII and LIX).
- Zeromski, J. 1970. Immunological findings in sensory carcinomatous neuropathy. Application of peroxidase labelled antibody. *Clin. Exp. Immunol.* **6**: 633-637.
- Trotter, J. L., B. A. Hendin, and C. K. Osterland. 1976. Cerebellar degeneration with Hodgkin disease. An immunological study. *Arch. Neurol.* **33**: 660-661.
- Gibbs, C. J., Jr., D. C. Gajdusek, D. M. Asher, M. P. Alpers, E. Beck, P. M. Daniel, and W. B. Matthews. 1968. Creutzfeldt-Jacob disease (spongiform encephalopathy): transmission to the chimpanzee. *Science (Wash. D. C.)* **161**: 388-389.
- Gajdusek, D. C. 1972. Slow virus infection and activation of latent infections in aging. *Adv. Gerontol. Res.* **4**: 201-218.
- Shreffler, D. C., and C. S. Davis. 1975. The H-2 major histocompatibility complex and the I immune response region: genetic variation, function, and organization. *Adv. Immunol.* **20**: 125-195.
- Gotze, D., R. A. Reisfeld, and J. Klein. 1973. Serologic evidence for antigens controlled by the *Ir* region in mice. *J. Exp. Med.* **138**: 1003-1008.