

## Postsynthetic deamidation of hemoglobin Providence (beta 82 Lys replaced by Asn, Asp) and its effect on oxygen transport.

S Charache, ... , R van Beneden, M Jessop

*J Clin Invest.* 1977;59(4):652-658. <https://doi.org/10.1172/JCI108683>.

### Research Article

Carriers of hemoglobin Providence have three types of beta chain in their hemolysates. The two abnormal chains have asparagine (Providence N, Prov N) or aspartic acid (Providence D) at position beta 82, instead of lysine. In vitro, only two beta chains are synthesized by reticulocytes of carriers, betaA and betaProv N. In vivo studies showed that the specific activity of Providence N was initially 10-fold higher than that of Providence D; the specific activities of the two labeled hemoglobins were approximately equal 5 wk after injection of isotope. Oxygen affinity of carriers' blood was somewhat increased, but they were not polycythemic. The affinity of the purified hemoglobins Providence was decreased. Addition of 2, 3 diphosphoglycerate had little effect on the affinity of either hemoglobin component, and addition of inositol hexaphosphate produced no change in the affinity of Providence D. These studies demonstrate that Providence N is deamidated to Providence D during the life span of the erythrocyte, and suggest this finding may represent only an easily observed prototype of posttranslational modification of proteins in general. Despite and abnormal P50 of the blood, oxygen transport is probably normal in carriers of the abnormal hemoglobins.

Find the latest version:

<https://jci.me/108683/pdf>



# Postsynthetic Deamidation of Hemoglobin Providence ( $\beta$ 82 Lys $\rightarrow$ Asn, Asp) and its Effect on Oxygen Transport

S. CHARACHE,\* J. FOX,† P. MCCURDY,§ H. KAZAZIAN, JR.,<sup>||</sup> and R. WINSLOW<sup>¶</sup>  
with the assistance of P. HATHAWAY, R. VAN BENEDEEN, and M. JESSOP

*From the Departments of Medicine\* and Pediatrics,<sup>||</sup> Johns Hopkins University, School of Medicine, Baltimore, Maryland 21205; Department of Pathology,† Providence Hospital, Washington, D. C. 20017; Georgetown University School of Medicine; and the Washington Regional Blood Program,§ American Red Cross, Washington, D. C. 20006; and Molecular Hematology Branch,<sup>¶</sup> National Heart and Lung Institute, Bethesda, Maryland 20014*

**ABSTRACT** Carriers of hemoglobin Providence have three types of  $\beta$  chain in their hemolysates. The two abnormal chains have asparagine (Providence N, Prov N) or aspartic acid (Providence D) at position  $\beta$  82, instead of lysine. In vitro, only two  $\beta$  chains are synthesized by reticulocytes of carriers,  $\beta^A$  and  $\beta^{\text{Prov N}}$ . In vivo studies showed that the specific activity of Providence N was initially 10-fold higher than that of Providence D; the specific activities of the two labeled hemoglobins were approximately equal 5 wk after injection of isotope.

Oxygen affinity of carriers' blood was somewhat increased, but they were not polycythemic. The affinity of the purified hemoglobins Providence was decreased. Addition of 2, 3 diphosphoglycerate had little effect on the affinity of either hemoglobin component, and addition of inositol hexaphosphate produced no change in the affinity of Providence D.

These studies demonstrate that Providence N is deamidated to Providence D during the life span of the erythrocyte, and suggest this finding may represent only an easily observed prototype of post-translational modification of proteins in general. Despite an abnormal  $P_{50}$  of the blood, oxygen transport is probably normal in carriers of the abnormal hemoglobins.

---

This paper was presented in part at the annual meeting of the American Society of Hematology. 1975. *Blood*. 46: 1030.

Address reprint requests to: Dr. Samuel Charache, Johns Hopkins Hospital, Baltimore, Md. 21205.

Received for publication 27 May 1976 and in revised form 29 October 1976.

## INTRODUCTION

McCurdy et al. (1) and Moo-Penn et al. (2) described hemoglobin Providence (Hb Prov)<sup>1</sup> after it was fortuitously discovered in a young black woman who had been hospitalized for hepatitis. The Hb was unusual because it occurred as two bands on electrophoresis; one (Hb Prov N)<sup>2</sup> was shown to have asparagine substituted for lysine at position  $\beta$  82 (2), while the other (Hb Prov D) contained aspartic acid at that position. Since genetic data indicate a single  $\beta$  chain locus in man, and because alteration of one base in the genetic code could not explain the change from lysine to aspartic acid, it was suggested that  $\beta^{\text{Prov D}}$  was produced by deamidation of  $\beta^{\text{Prov N}}$ . The position of amino acid substitution ( $\beta$  82) is a 2,3 diphosphoglycerate (DPG) binding site, and it was also suggested that oxygen transport might be abnormal in carriers.

In this paper we present what we believe to be the first demonstration of functionally significant post-synthetic deamidation of human Hb. We also present evidence that a change in Hb concentration must be but one of several mechanisms of compensation for altered oxygen affinity.

---

<sup>1</sup> These abbreviations are based on the one-letter code for amino acids. Dayhoff, M. O., 1972. Atlas of Protein Sequence and Structure. Vol. 5. National Biochemical Research Foundation, Silver Spring, Md. D-2.

<sup>2</sup> Abbreviations used in this paper: DPG, 2,3 diphosphoglycerate; HB, hemoglobin; IHP, inositol hexaphosphate; Prov, Providence;  $P_{50}$ , oxygen pressure required for 50% saturation.

TABLE I  
Hematologic Data from Carriers of Hb Prov

Pedigree number	Age	Hct	Hb	RBC*	Retic	Prov N†	Prov D†	DPG
	yr	liter/liter	g/dl	10 <sup>12</sup> /liter	%	%	%	mol/mol Hb
III-3	25	0.470	16.6	4.77	1.2	22	45	0.75
-5	18	0.450	16.7	4.93	1.6	13	55	0.82
IV-2	1	0.435	13.9	—	1.2	13	56	0.85
-3	2	0.422	13.2	—	1.0	14	55	0.89

\* RBC, erythrocyte count.

† Measured by electrophoresis at pH 8.6.

## METHODS

All blood samples were collected in EDTA, with the exception of those used for studies of Hb synthesis *in vitro*, which were heparinized. Erythrocyte mass, and erythrocyte survival, were measured by standard techniques, with <sup>51</sup>Cr. The regression of log dpm/ml blood on time was calculated by the method of least squares. Electrophoresis was carried out on cellulose acetate and agar plates (Titan III and IV, Helena Laboratories, Beaumont, Tex.) at pH 8.6 and 6.0, respectively. Hb components were separated on DEAE-Sephadex (3), with a pH gradient from 7.8 to 6.8; 2 liters of buffer were used for each 2.5 × 12 cm column. Buffers contained KCN when samples were used for measurement of radioactivity, and they contained CO when oxygen affinity was to be measured. The latter samples were rechromatographed, exchanged through Sephadex G-25 into 0.05 M bis-Tris 0.10 M NaCl buffers, (Pharmacia Fine Chemicals Inc., Piscataway, N. J.) and the CO was removed by flash photolysis (4). In all studies, Hb A, isolated from the same blood sample, was used as a control. The proportions of Hb Prov N and Hb Prov D were estimated by elution from cellulose acetate strips (Sephaphor III, Gelman Instrument Co., Ann Arbor, Mich.), and by estimating the area under peaks on chromatograms. Stability was estimated by incubation in 17% isopropanol in 0.1 M Tris buffer at pH 7.4 and 37° (5), and by incubation in 0.1 M phosphate pH 7.0 at 55°C (6).

*In vitro* studies of Hb synthesis were carried out by incubating washed erythrocytes with [<sup>3</sup>H]leucine (7). In some experiments, the radioactive hemolysate was chromatographed on DEAE Sephadex, and globin was prepared from purified Hb fractions; in other studies, the whole hemolysate was used. <sup>14</sup>C-labeled normal Hb was added to some samples as an internal control; in one series of studies it was added to a nonradioactive hemolysate from the proband and incubated overnight before globin was prepared. Polypeptide chains were separated by chromatography in 8 M urea (8). Aliquots of each fraction were added to Hydromix (Yorktown Research Inc., S. Hackensack, N. J.), and counted in a Nuclear Chicago Unilux II liquid scintillation counter.

*In vivo* studies of Hb metabolism were done by intravenous injection of 50 μCi of [<sup>14</sup>C]glycine solution into the proband, after informed consent was obtained. Hb fractions from DEAE-Sephadex were concentrated, and 15 mg (Hb A<sub>2</sub>) to 200 mg (major components) aliquots were dried on paper cones (Combusto-Cone, Packard Instrument Co., Inc., Downers Grove, Ill.). These were oxidized to <sup>14</sup>CO<sub>2</sub> with >99% recovery (Pemlab, LeGrange, Ill.), and counted.

Whole blood oxygen affinity was measured after equilibration with analyzed mixtures of O<sub>2</sub>, CO<sub>2</sub>, and N<sub>2</sub> by previously described methods (4). DPG was measured with commercial kits (DPG Stat-Pak, Calbiochem, San Diego, Calif.). DPG depletion in erythrocytes was accomplished by 12–18 h incubation at 37°C; the pH of these samples was adjusted by addition of three drops of 2 N NaOH to the plasma from 14 cubic centimeters of blood, with subsequent remixing of the alkalized plasma and erythrocytes. In another series of experiments, oxygen affinity of whole blood was measured by an automated technique which permits precise recording of the upper and lower ends of the dissociation curve.<sup>3</sup>

Oxygen affinity of 1.5 × 10<sup>-5</sup> M Hb solutions in 0.05 M bis-Tris, 0.1 M NaCl at 25°C was measured in a cell designed by Imai et al. (9), with a Cary 118C spectrophotometer. Methemoglobin reductase (10) was added to each sample, and samples were scanned after deoxygenation; results were discarded if a peak of optical density was present at 630 nm. Optical density at 560 nm was automatically plotted as a function of PO<sub>2</sub> on an X-Y recorder; points were manually picked from these curves and the linear regression of log S/1-S (where S is saturation as a decimal fraction) on log PO<sub>2</sub> was calculated between S = 0.2 and 0.8. The Bohr effect was calculated from the linear regression of log P<sub>50</sub> on pH, generally between pH 6.5 and 7.5. Inositol hexaphosphate (IHP) (Sigma Chemical Co., St. Louis, Mo.) and DPG (Calbiochem) were added as 1.6–2.6 mM solutions after the pH was adjusted to 7.0 with dilute NaOH; the pentacyclohexylammonium salt of DPG was first converted to the free acid by passage through AG 50W-X8 resin (Bio-Rad Laboratories, Richmond, Calif.).

The pH gradient across the erythrocyte membrane was estimated by measuring plasma pH after equilibration of 4 ml of blood with a PCO<sub>2</sub> about 40 torr for 20 min at 37°C, and centrifugation for 10 min at 2,600 g in a stoppered 5 ml glass test tube. The plasma was removed, the tube restoppered, and the erythrocytes lysed by freezing (in dry ice-acetone) and thawing (in warm water) three times over a period of 10 min. The tubes were agitated only gently during this period, to minimize diffusion of CO<sub>2</sub> into the gas phase. The pH of the erythrocyte lysate was measured by aspiration from the bottom of the tube.

<sup>3</sup> Winslow, R. M., M. L. Swenberg, R. L. Berger, R. I. Shrager, M. Luzzanna, M. Samaja, and L. Rossi-Bernardi. The oxygen equilibrium curve of normal human blood and its evolution in terms of Adair's equation. *J. Biol. Chem.* In press.

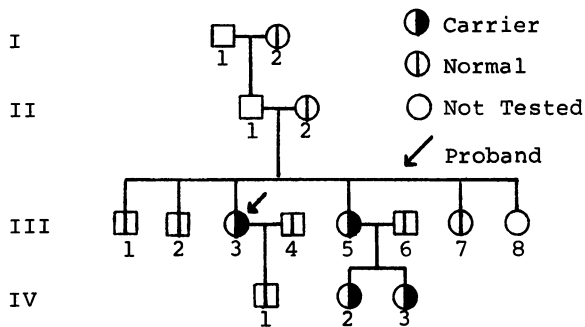

FIGURE 1 Family of the proband.

No correction was made for trapped plasma, and the gradient was calculated from  $\Delta\text{pH} = \text{pH plasma} - \text{pH erythrocyte lysate}$ .

## RESULTS

**Clinical studies.** Data collected from the patient and her family are given in Table I and Fig. 1. Their erythrocytes appeared normal on smears. The proband's erythrocyte mass was 1,830 ml; the expected normal range for her height and weight was 1,015–1,878 ml. The  $^{51}\text{Cr}$  half-life of her erythrocytes was 23.5 days (normal 25–35 days). Similar values for her sister were erythrocyte mass 1,702 ml (expected 990–1,843); and  $t_{1/2}$  22.2 days. Serum haptoglobin and hemopexin concentrations were normal in both women. A normal karyotype was obtained from lymphocytes in the proband's blood, by Dr. D. Borgoankar.

**Hemoglobin metabolism.** Hbs. Prov N and Prov D were readily demonstrated by electrophoresis on cellulose acetate (Fig. 2) and by chromatography (Fig. 3). The purified Hb showed slightly increased precipitation, compared to normal and sickle cell trait hemolysates, after incubation in isopropanol-Tris and phosphate buffers. After electrophoresis

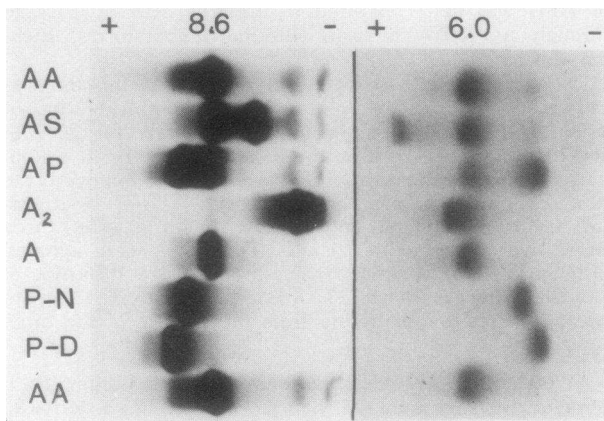

FIGURE 2 Electrophoresis on cellulose acetate at pH 8.6 (left) and agar at pH 6.0 (right).

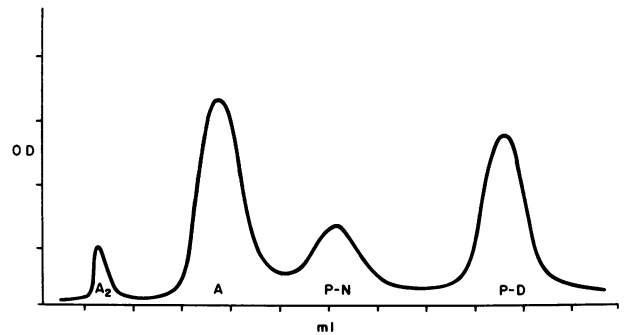

FIGURE 3 Chromatographic separation of Hb components from the proband's hemolysate, on DEAE Sephadex. P-N, Hb Prov N; P-D, Hb Prov D.

and elution from cellulose acetate strips, the proportion of Hb Prov N in the proband's blood was 22% and Hb Prov D, 45%. The proportions in her sister's blood were 31 and 48%. After chromatography of the proband's hemolysate on DEAE Sephadex (Fig. 3), the proportions were 20 and 34%, while after chromatography of globin in 8 M urea on CM cellulose, the proportions of the two Prov  $\beta$  chains were 20 and 41%. These results, obtained with fresh samples, did not differ from those obtained with samples stored at 4°C for 2 wk.

After incubation of the proband's erythrocytes for 1 h with [ $^3\text{H}$ ]leucine, very little radioactivity appeared in  $\beta$  Prov D, while  $\beta^A$  and  $\beta^{\text{Prov N}}$  were highly labeled. After purification of the three Hbs, the  $\alpha$  and  $\beta$  chains of Hbs A and Prov N still demonstrated radioactivity, while only a few counts were present in the  $\alpha$  chain of Prov D and essentially none in the  $\beta$  chain (4). When radioactive Hb A was incubated with a nonradioactive hemolysate from the proband, similar amounts of radioactivity were found in the  $\alpha$  chains, suggesting that the radioactivity in  $\alpha^{\text{Prov D}}$  was due to exchange of subunits between Hb components. The  $\beta/\alpha$  synthetic ratio, where  $\beta^2 = \beta^A + \beta^{\text{Prov N}} + \beta^{\text{Prov D}}$ , was 1.3 in the experiment shown in Fig. 4; in others it was higher. Peptide maps of  $\alpha$  and  $\beta$  chains, from the purified Hb, showed radioactive peptides only where anticipated, i.e.  $\beta$  peptides of Hb A and Prov N containing leucine were labeled while those of Hb Prov D were not.  $\beta/\alpha$  ratios greater than 1 are usually taken as evidence of  $\alpha$  thalassemia, but the patients' erythrocytes were normocytic and normochromic, and the proportion of Hb Prov was unusually high, rather than low. After washing incubated erythrocytes, and reincubating with nonradioactive leucine for 6 h, there was little suggestion of a redistribution of radioactivity between the two Prov chains, suggesting that post-translational modification occurs slowly within the erythrocyte.

[<sup>14</sup>C]glycine was injected into the proband and blood samples were collected for 35 days thereafter. The hemoglobins were separated on DEAE Sephadex and the fractions oxidized to <sup>14</sup>CO<sub>2</sub>—thereby measuring glycine incorporation into heme as well as globin. Specific radioactivity (dpm/g Hb) was measured as a function of time after injection. The results shown in Fig. 5 are calculated on the assumption that the patient's Hb concentration, and the proportions of Prov N and D in her hemolysate, remained constant during the experiment. Although the specific activities of Hbs A and A2 were equal and constant (85 dpm/g) throughout the experiment, that of Prov N was initially higher (181 dpm/g) and that of Prov D was lower (14 dpm/g). Specific activities of the two abnormal components were approximately equal on the 35th day after injection of glycine.

**Oxygen affinity: blood.** Oxygen affinity of the proband's blood was increased; the P<sub>50</sub> calculated after equilibration with analyzed gas mixtures was 21.1 torr at 37°C and pH 7.4, and n (a measure of heme—heme interaction) was 2.86 (normal P<sub>50</sub> 26.6 torr, n 2.6–2.8). Her sister's blood yielded almost identical results. The Bohr effect was assumed to be

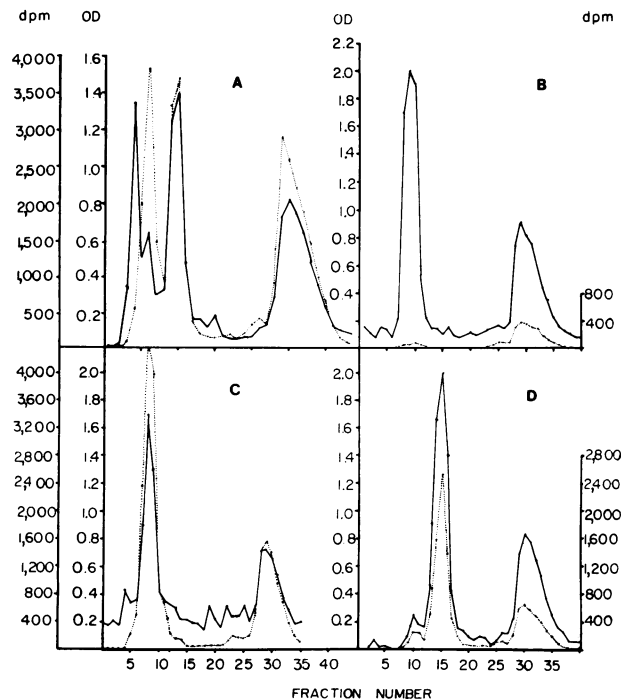

FIGURE 4 Chromatographic separation of  $\alpha$  and  $\beta$  chains from the proband's hemolysate, on CM cellulose. Radioactivity was incorporated during a 1-h incubation with [<sup>3</sup>H]-leucine (see text). Optical density (—) and <sup>3</sup>H-radioactivity (···) are shown for (A) whole hemolysate; (B) Hb Prov D; (C) Hb Prov N; and (D) Hb A. In panel (A), the peaks are, from left to right  $\beta^{\text{prov D}}$ ,  $\beta^{\text{prov N}}$ ,  $\beta^{\text{A}}$ , and  $\alpha$ .

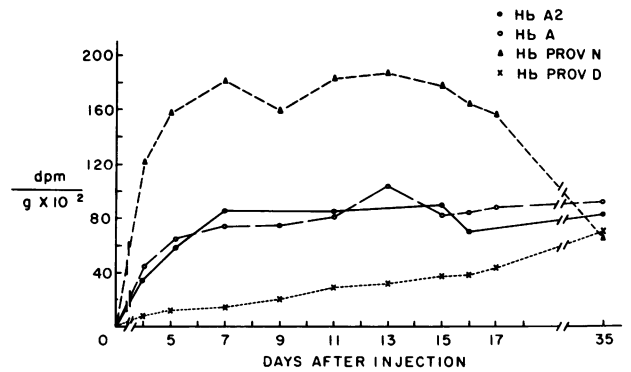

FIGURE 5 Specific activity of Hb components after intravenous injection of [<sup>14</sup>C]glycine.

normal in these calculations; that assumption is incorrect for both Hbs Prov, but the error is quite small, for the actual pH of the samples was 7.395–7.400. Oxygen affinity was also measured with an automated device at pH 7.40 and PCO<sub>2</sub> 40 torr (Fig. 6). The P<sub>50</sub> was 22.5 torr, and the maximal value of n 3.12.

Simultaneous studies with purified solutions of Hb suggested that the increased oxygen affinity of the proband's blood was due to its low reactivity with DPG (see below). To test that hypothesis, the oxygen affinity of DPG-depleted erythrocytes was measured. After incubation at 37°C for 12 h, the DPG concentration in erythrocytes fell to zero (Table II). Oxygen affinity of the proband's blood increased but n decreased; there was no methemoglobin in the incubated sample. The oxygen affinity of control blood increased to an even greater extent, and incubated normal erythrocytes had almost the same P<sub>50</sub> as

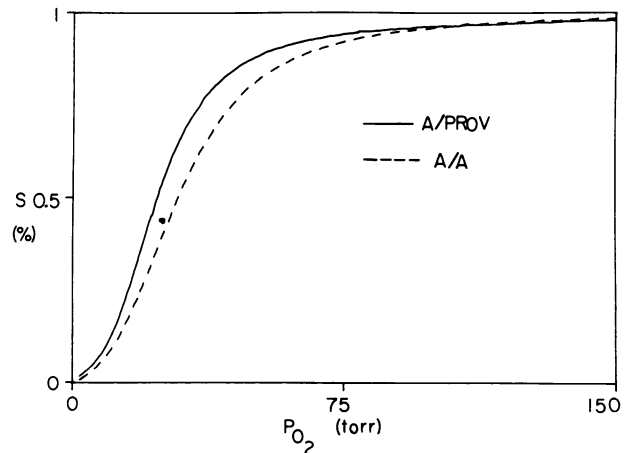

FIGURE 6 Continuous recordings of the oxygen affinity of blood, measured at 37°C, PCO<sub>2</sub> 40 torr, and pH 7.40. A/Prov, blood of proband; A/A, normal blood.

TABLE II  
Comparison of Oxygen Affinity of Fresh and DPG-depleted Blood with that of Stripped Hemolysate

	Fresh blood					DPG-depleted blood				Stripped hemolysate		
	DPG	P <sub>50</sub>	n	ΔpH*	MCHC†	P <sub>50</sub>	n	ΔpH*	MCHC†	P <sub>50</sub>	n	pH
	mol/molHb	torr			g/dl	torr			g/dl	torr		
Proband	0.75	21.1	2.86	0.20	35.8	16.0	1.95	0.13	34.7	12.0	2.2	7.27
Control	0.83	26.6	2.60	0.22	37.0	16.5	2.76	0.12	34.0	10.1	1.8	7.33

\* Measurements made at a plasma pH of 7.41–7.48.

† Based on microhematocrit.

incubated blood from the proband; heme-heme interaction did not change in the normal blood.

If DPG were the only factor modulating oxygen affinity, the P<sub>50</sub> of DPG-depleted erythrocytes should be the same as that of a dilute stripped hemolysate, studied at the same temperature, and at the internal pH of the erythrocyte. The latter was estimated from measurements of plasma pH, and the ΔpH across the erythrocyte membrane (Table II). The P<sub>50</sub> of control hemolysates was lower than that of DPG-depleted control erythrocytes, in accord with previous suggestions (11) that CO<sub>2</sub> (present in the gas mixtures used with erythrocytes, but not the hemolysates) exerts an effect on oxygen affinity independent of pH. The affinity of the proband's hemolysate was lower than that of the control, suggesting that the effect of CO<sub>2</sub>, differences in salt composition (bis-Tris NaCl vs. the internal milieu of the erythrocyte) (12), and possibly Hb concentration had different effects on Hb A and the Hbs Prov.

**Oxygen affinity: purified Hb.** Purified Hbs Prov N and Prov D exhibited decreased oxygen affinity and a decreased Bohr effect (Fig. 7), Hb Prov D being more abnormal. Heme-heme interaction was decreased, and varied slightly with pH. Hb Prov N showed little change in oxygen affinity when DPG was added, but did change with IHP; Hb Prov D showed little change with either effector (Fig. 8). When the sodium chloride concentration of the buffer was increased (Table III), the P<sub>50</sub> of Hb Prov D did not change as much as that of Hb A or Hb Prov N.

## DISCUSSION

The data indicate that Hb Prov N undergoes deamidation to Hb Prov D during the life span of the erythrocyte. Essentially only two β chains are synthesized, β<sup>A</sup> and β<sup>Prov N</sup> (Fig. 4). Deamidation could not be demonstrated during a 6-h chase in vitro with nonradioactive leucine, but was shown during the 5 wk after injection of [<sup>14</sup>C] glycine into the proband (Fig. 5). Although heme exchange (13) between β chains might have factitiously influenced this result, the relatively constant specific activity of Hb A, and the studies of Hb synthesis, make that an unlikely hypothesis. Other proteins and polypeptides undergo spontaneous deamidation (14) and Hb Wayne has recently been reported to exhibit this property (15). It is not clear why asparagine β 82 in Hb Prov deamidates, while the other asparagine residues do not. The half-life of Hb Prov N in vivo was between 17 and 35 days, a time period not dissimilar to those observed with synthetic polypeptides (14). Rates of deamidation of proteins depend upon temperature, buffer composition, pH, and tertiary structure. In synthetic polypeptides, a neighboring histidine or glycine appears to foster deamidation; if asparagine β 82 occupies the same spatial position in Hb Prov N as lysine does in normal Hb (16) it is between two histidines, and next to a glycine. A comparison with hemoglobin Singapore is of particular interest in this regard, for that hemoglobin also contains two amino acid substitutions (α 78 Asn → Asp, α 79 Ala → Gly). It has been suggested that only the sub-

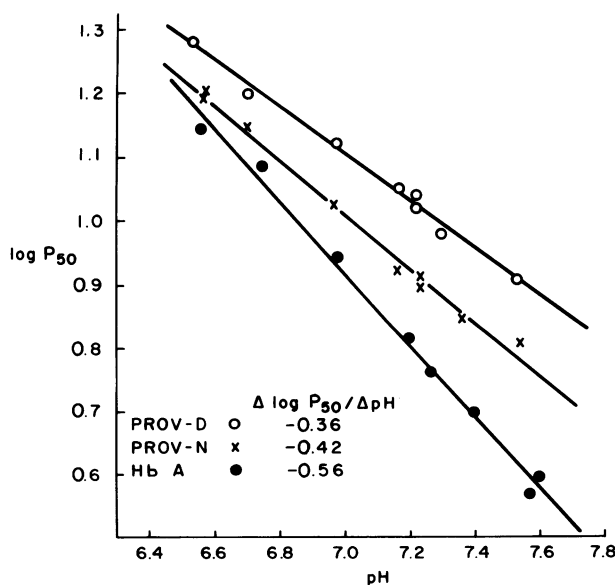

FIGURE 7 Bohr effect of purified Hb.

stitution of glycine for alanine is the result of a mutation, and that the new glycine may be responsible for deamidation of the neighboring asparagine to aspartic acid (17).

Hemolysates contain more than 50% Hb(s) Prov, as is the case with several (but not all) fast  $\beta$  chain variants (18–22). Some of the fast component is probably Hbs  $A_{1\alpha-c}$  (23) which comprise 4–9% of normal hemolysates—but those fast-moving subfractions are produced after erythrocytes are released into the circulation (24), and our studies indicate that synthesis of  $\beta$  Prov N and D is somewhat greater than that of  $\beta^A$  (Table II). No explanation can be offered, nor can we explain why somewhat more  $\beta$  than  $\alpha$  chains are synthesized. Usually that would be considered as evidence for coexisting  $\alpha$  thalassemia, but then a lower proportion of Hbs Prov would be expected (25).

Position  $\beta 82$  is part of the DPG binding site in normal Hb (16). The data presented here indicate that substitution of an uncharged asparagine residue, or a negatively charged aspartic acid side chain, for a positively charged lysine diminishes the effect of organic phosphates and presumably interferes with their binding. The latter substitution also alters the effect of NaCl on oxygen affinity. Increased oxygen affinity of the patient's blood is probably caused by the low reactivity of Hb Prov with DPG, just as the increased oxygen affinity of umbilical cord blood reflects nonbinding of DPG to fetal Hb (26, 27). After complete depletion of DPG within erythrocytes, the oxygen affinity of the proband's blood was similar to that of depleted normal blood.

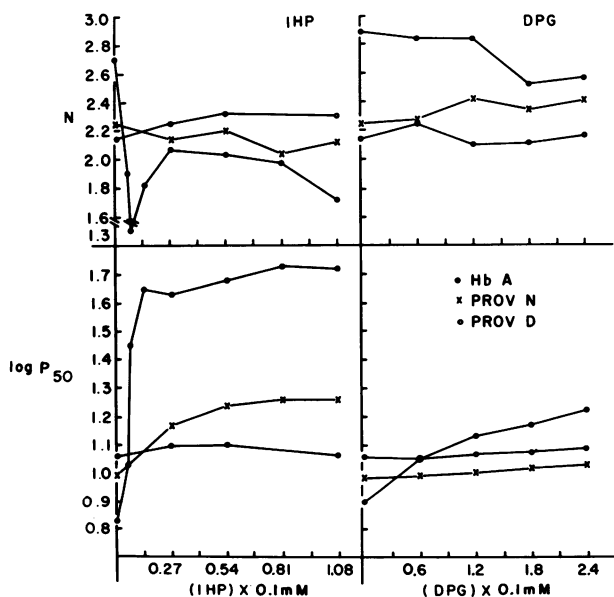

FIGURE 8 Oxygen affinity and heme-heme interaction after addition of IHP and DPG. Dissociation curves were biphasic at low concentrations of IHP.

TABLE III  
Effect of NaCl Concentration on Oxygen Affinity  
at pH 6.9–7.1

Buffer	Hb A		Hb Prov N		Hb Prov D	
	n	$P_{50}$	n	$P_{50}$	n	$P_{50}$
0.05 M bis-Tris plus						
0.05 M NaCl	2.52	6.66	1.99	8.32	1.72	8.40
0.10 M NaCl	2.86	7.43	2.55	13.90	2.24	13.80
0.15 M NaCl	2.56	11.43	2.07	12.50	1.69	10.98
0.20 M NaCl	2.39	12.67	1.95	13.50	1.77	11.90

No explanation for the low affinity of the purified Hbs Prov is evident from our data. It would seem likely that a new bond or bonds are formed in the deoxy (T) conformation (28) or that bonds normally present in the oxy (R) conformation are not formed, disturbing their relative concentrations and shifting the balance toward the low affinity T state.

Interesting comparisons can be made between the Hbs Prov and Hbs Rahere (29) and Little Rock (30). In Hb Rahere, residue  $\beta 82$  is changed to threonine. Whole blood oxygen affinity is increased ( $P_{50} = 18$  torr), for the same reason as in our patients, but affinity of the purified DPG-free Hb is the same as that of Hb A studied under similar conditions. The erythrocyte mass of a carrier of Hb Rahere was within the normal range, as it was in our patients, suggesting that oxygen transport is normal in both hemoglobinopathies. The dissociation curve of our proband was not biphasic (an unexpected finding, for the major effect of DPG is exerted at low oxygen saturations [31]), and oxygen delivery must be maintained by nonhematopoietic adjustments.

Hb Little Rock, which is produced by amino acid substitution at a different DPG binding site, does produce polycythemia. The effect of DPG is decreased, but the affinity of the purified Hb is increased because of a new bond which stabilizes the high affinity R conformation. As a result, erythrocyte  $P_{50}$  is quite low and polycythemia is striking (32).

These data demonstrate significant deamidation of a protein in vivo. Post-translational glycosylation of Hb has also been described (33); those observations and ours, probably reflect the ease with which Hb can be studied, rather than a property peculiar to the molecule. Deamidation may be a fairly common event, and may be related to the process of cell senescence (34). Functional changes in the patients' erythrocytes, produced by these interesting changes at an important DPG binding site, are quite small and are clinically insignificant; they would not have been discovered if the proband's blood had not erroneously been sent for Hb, rather than serum protein, electrophoresis.

## ACKNOWLEDGMENTS

Dr. D. Borgoankar of the Department of Medicine, Johns Hopkins University School of Medicine, prepared and analyzed the proband's karyotype, and Dr. W. Zinkham of the Department of Pediatrics, Johns Hopkins University School of Medicine, measured haptoglobin and hemopexin concentrations.

This work was supported by grants HL02799, HL14131, RCDA-AM70669, and AM13983.

## REFERENCES

1. McCurdy, P. R., J. Fox, and W. Moo-Penn. 1975. Apparent duplication of the  $\beta$ -chain gene in man. *Am. J. Hum. Genet.* **27**: 62A. (Abstr.)
2. Moo-Penn, W. F., D. L. Jue, K. C. Bechtel, M. H. Johnson, R. M. Schmidt, P. R. McCurdy, J. Fox, J. Bonaventura, J. B. Sullivan, and C. Bonaventura. 1976. Hemoglobin Providence: a human hemoglobin variant occurring in 2 forms in vivo. *J. Biol. Chem.* **251**: 7557-7562.
3. Huisman, T. H. J., and A. M. Dozy. 1965. Studies on the heterogeneity of hemoglobin. The use of tris-(Hydroxymethyl)aminomethane-HCl buffers in the anion-exchange chromatography of hemoglobins. *J. Chromatogr.* **19**: 160-169.
4. Winslow, R. M., and S. Charache. 1975. Hemoglobin Richmond. Subunit dissociation and oxygen equilibrium properties. *J. Biol. Chem.* **250**: 6939-6942.
5. Carrell, R. W., and R. Kay. 1972. A simple method for the detection of unstable hemoglobins. *Br. J. Haematol.* **23**: 615-619.
6. Charache, S., A. M. Mondzac, and U. Gessner. 1969. Hemoglobin Hasharon ( $\alpha_2^{47\text{His}}$  [CD5]  $\beta_2$ ): A hemoglobin found in low concentration. *J. Clin. Invest.* **48**: 834-847.
7. Schwartz, E. 1974. Abnormal globin synthesis in thalassemic red cells. *Semin. Hematol.* **11**: 549-567.
8. Clegg, J. B., M. A. Naughton, and D. J. Weatherall. 1966. Abnormal human haemoglobins. Separation and characterization of the  $\alpha$  and  $\beta$  chains by chromatography, and the determination of two new variants, Hb Chesapeake and Hb J (Bangkok). *J. Mol. Biol.* **19**: 91-108.
9. Imai, K., H. Morimoto, M. Kotani, H. Watari, W. Hirata, and M. Kuroda. 1970. Studies on the function of abnormal hemoglobins. I. An improved method of automatic measurement of the oxygen equilibrium curve of hemoglobin. *Biochim. Biophys. Acta.* **200**: 189-196.
10. Hayashi, A., T. Suzuki, and M. Shin. 1973. An enzymatic reduction system for metmyoglobin and methemoglobin and its application to functional studies of oxygen carriers. *Biochim. Biophys. Acta.* **310**: 309-316.
11. Kilmartin, J. V., and L. Rossi-Bernardi. 1973. Interaction of hemoglobin with hydrogen ions, carbon dioxide, and organic phosphates. *Physiol. Rev.* **53**: 836-890.
12. Antonini, E., G. Amiconi, and M. Brunori. 1972. The effect of anions and cations on the oxygen equilibrium of human hemoglobin. In *Oxygen Affinity of Hemoglobin and Red Cell Acid Base Status*, M. Rorh and P. Astrup, eds. Academic Press Inc., New York. 121-129.
13. Bunn, H. F., and J. H. Jandl. 1966. Exchange of heme among hemoglobin molecules. *Proc. Natl. Acad. Sci. U. S. A.* **56**: 974-978.
14. Robinson, A. B., and C. J. Rudd. 1974. Deamidation of glutaminyl and asparaginyl residues in peptides and proteins. *Curr. Top. Cell. Regul.* **8**: 247-295.
15. Hanash, S. M., and D. L. Rucknagel. 1975. Biosynthesis of Hb Wayne in reticulocytes. *Am. J. Hum. Genet.* **27**: 42A. (Abstr.)
16. Amone, A. 1972. X-ray diffraction study of binding of 2,3-diphosphoglycerate to human deoxyhaemoglobin. *Nature (Lond.)*. **237**: 146-149.
17. Lehmann, H., and A. Lang. 1974. Various aspects of  $\alpha$ -thalassemia. *Ann. N.Y. Acad. Sci.* **232**: 152-158.
18. Pootrakul, S., P. Wasi, and S. Na-Nakorn. 1967. Haemoglobin J-Bangkok: a clinical, haematological and genetical study. *Br. J. Haematol.* **13**: 303-309.
19. Takeda, I. 1964. Hemoglobin Hikari  $\alpha_2^A \beta_2^{61\text{AspNH}_2}$  a new abnormal hemoglobin detected from two unrelated Japanese families. *Bull. Yamaguchi Med. School.* **10**: 87-98.
20. Thorup, O. A., H. A. Itano, M. Wheby, and B. S. Leavell. 1956. Hemoglobin J. *Science (Wash. D. C.)*. **123**: 889-890.
21. Weatherall, D. J. 1964. Hemoglobin J (Baltimore) co-existing in a family with hemoglobin S. *Bull. Johns Hopkins Hosp.* **114**: 1-12.
22. Wong, S. C., N. Bouver, J. B. Wilson, and T. H. J. Huisman. 1971. Hb-J-Georgia = Hb-J-Baltimore =  $\alpha_2 \beta_2$  16 Gly  $\rightarrow$  Asp. *Clin. Chim. Acta.* **35**: 521-522.
23. Trivelli, L. A., H. M. Ranney, and H.-T. Lai. 1971. Hemoglobin components in patients with diabetes mellitus. *N. Engl. J. Med.* **284**: 353-357.
24. Haney, D. N., H. F. Bunn, S. Kamen, K. Gabbay, and P. M. Gallop. 1975. Structural and biosynthetic studies on hemoglobin A<sub>1c</sub>. *Blood.* **46**: 1051. (Abstr.)
25. Charache, S., C. L. Conley, T. D. Doebelin, and M. Bartalos. 1974. Thalassemia in black Americans. *Ann. N. Y. Acad. Sci.* **232**: 125-134.
26. Maurer, H. S., R. E. Behrman, and G. R. Honig. 1970. Dependence of the oxygen affinity of blood on the presence of foetal or adult haemoglobin. *Nature (Lond.)*. **227**: 388-390.
27. Versmold, H., G. Seifert, and K. P. Riegel. 1973. Blood oxygen affinity in infancy: the interaction of fetal and adult hemoglobin, oxygen capacity, and red cell hydrogen ion and 2,3-diphosphoglycerate concentration. *Respir. Physiol.* **18**: 14-25.
28. Perutz, M. F. 1970. Stereochemistry of cooperative effects in haemoglobin. *Nature (Lond.)*. **228**: 726-734.
29. Lorkin, P. A., A. D. Stephens, M. E. J. Beard, P. F. M. Wrigley, L. Adams, and H. Lehmann. 1975. Haemoglobin Rahere ( $\beta$  82 Lys-Thr): a new high affinity haemoglobin associated with decreased 2,3-diphosphoglycerate binding and relative polycythaemia. *Br. Med. J.* **4**: 200-202.
30. Perutz, M. F. 1973. Stereochemical interpretation of high oxygen affinity of haemoglobin Little Rock ( $\alpha_2 \beta_2$  143 His  $\rightarrow$  Gln). *Nat. New Biol.* **243**: 180.
31. Tyuma, I., K. Shimizu, and K. Imai. 1971. Effect of 2,3-diphosphoglycerate on the cooperativity in oxygen binding of human adult hemoglobin. *Biochem. Biophys. Res. Commun.* **43**: 423-428.
32. Bromberg, P. A., F. Padilla, J. T. Guy, and S. P. Balcerzak. 1972. Effect of hemoglobin Little Rock on the physiology of oxygen delivery. *Chest.* **61** (Suppl.): 145. (Abstr.)
33. Koenig, R. J., and A. Cerami. 1975. Synthesis of hemoglobin A<sub>1c</sub> in normal and diabetic mice: potential model of basement membrane thickening. *Proc. Natl. Acad. Sci. U. S. A.* **72**: 3687-3691.
34. Robinson, A. B., J. H. McKerrow, and P. Cary. 1970. Controlled deamidation of peptides and proteins: an experimental hazard and a possible biological timer. *Proc. Natl. Acad. Sci. U. S. A.* **66**: 753-757.