

L-Carnitine in omnivorous diets induces an atherogenic gut microbial pathway in humans

Robert A. Koeth,^{1,2,3} Betzabe Rachel Lam-Galvez,⁴ Jennifer Kirsop,^{1,2} Zeneng Wang,^{1,2} Bruce S. Levison,¹ Xiaodong Gu,^{1,2} Matthew F. Copeland,⁴ David Bartlett,¹ David B. Cody,⁴ Hong J. Dai,⁵ Miranda K. Culley,¹ Xinmin S. Li,^{1,2} Xiaoming Fu,^{1,2} Yuping Wu,⁶ Lin Li,^{1,2} Joseph A. DiDonato,^{1,2} W.H. Wilson Tang,^{1,2,3} Jose Carlos Garcia-Garcia,⁴ and Stanley L. Hazen^{1,2,3}

¹Department of Cellular and Molecular Medicine, Lerner Research Institute, ²Center for Microbiome and Human Health, and ³Department of Cardiovascular Medicine, Cleveland Clinic, Cleveland, Ohio, USA.

⁴Life Sciences TPT and ⁵Global Biosciences, The Procter & Gamble Company, Cincinnati, Ohio, USA. ⁶Department of Mathematics, Cleveland State University, Cleveland, Ohio, USA.

BACKGROUND. L-Carnitine, an abundant nutrient in red meat, accelerates atherosclerosis in mice via gut microbiota-dependent formation of trimethylamine (TMA) and trimethylamine *N*-oxide (TMAO) via a multistep pathway involving an atherogenic intermediate, γ -butyrobetaine (γ BB). The contribution of γ BB in gut microbiota-dependent L-carnitine metabolism in humans is unknown.

METHODS. Omnivores and vegans/vegetarians ingested deuterium-labeled L-carnitine (d_3 -L-carnitine) or γ BB (d_3 - γ BB), and both plasma metabolites and fecal polymicrobial transformations were examined at baseline, following oral antibiotics, or following chronic (≥ 2 months) L-carnitine supplementation. Human fecal commensals capable of performing each step of the L-carnitine $\rightarrow\gamma$ BB \rightarrow TMA transformation were identified.

RESULTS. Studies with oral d_3 -L-carnitine or d_3 - γ BB before versus after antibiotic exposure revealed gut microbiota contribution to the initial 2 steps in a metaorganismal L-carnitine $\rightarrow\gamma$ BB \rightarrow TMA \rightarrow TMAO pathway in subjects. Moreover, a striking increase in d_3 -TMAO generation was observed in omnivores over vegans/vegetarians (>20 -fold; $P = 0.001$) following oral d_3 -L-carnitine ingestion, whereas fasting endogenous plasma L-carnitine and γ BB levels were similar in vegans/vegetarians ($n = 32$) versus omnivores ($n = 40$). Fecal metabolic transformation studies, and oral isotope tracer studies before versus after chronic L-carnitine supplementation, revealed that omnivores and vegans/vegetarians alike rapidly converted carnitine to γ BB, whereas the second gut microbial transformation, γ BB \rightarrow TMA, was diet inducible (L-carnitine, omnivorous). Extensive anaerobic subculturing of human feces identified no single commensal capable of L-carnitine \rightarrow TMA transformation, multiple community members that converted L-carnitine to γ BB, and only 1 Clostridiales bacterium, *Emergencia timonensis*, that converted γ BB to TMA. In coculture, *E. timonensis* promoted the complete L-carnitine \rightarrow TMA transformation.

CONCLUSION. In humans, dietary L-carnitine is converted into the atherosclerosis- and thrombosis-promoting metabolite TMAO via 2 sequential gut microbiota-dependent transformations: (a) initial rapid generation of the atherogenic intermediate γ BB, followed by (b) transformation into TMA via low-abundance microbiota in omnivores, and to a markedly lower extent, in vegans/vegetarians. Gut microbiota γ BB \rightarrow TMA/TMAO transformation is induced by omnivorous dietary patterns and chronic L-carnitine exposure.

TRIAL REGISTRATION. ClinicalTrials.gov NCT01731236.

FUNDING. NIH and Office of Dietary Supplements grants HL103866, HL126827, and DK106000, and the Leducq Foundation.

Conflict of interest: ZW, BSL, and SLH are named as co-inventors on pending and issued patents held by the Cleveland Clinic relating to cardiovascular diagnostics and therapeutics, and have the right to receive royalty payment for inventions or discoveries related to cardiovascular diagnostics or therapeutics from Cleveland HeartLab, Quest Diagnostics, and Procter & Gamble. SLH also reports having been paid as a consultant by Procter & Gamble, and having received research funds from Procter & Gamble and Roche. BRLG, MFC, DBC, HJD, and JCGG are employees of Procter & Gamble and are named as co-inventors on patents relevant to this work.

License: Copyright 2019, American Society for Clinical Investigation.

Submitted: July 28, 2017; **Accepted:** October 30, 2018.

Reference information: *J Clin Invest.* 2019;129(1):373–387.

https://doi.org/10.1172/JCI94601.

Introduction

Recent studies identify a mechanistic link between a Western diet, gut microbiota-dependent metabolism, and development of both cardiovascular disease (CVD) and metabolic diseases (1–3). For example, the ingestion of trimethylamine-containing (TMA-containing) dietary nutrients enriched in animal products such as choline, phosphatidylcholine, and L-carnitine can serve as precursor for the ultimate generation of an atherogenic metabolite, trimethylamine *N*-oxide (TMAO), via a metaorganismal pathway involving initial gut microbial formation of TMA, followed by host hepatic conversion of TMA into TMAO (4–8). Elevated plas-

ma TMAO concentrations predict incident CVD risks in multiple clinical cohorts (4–7, 9–14), and both animal models with microbial transplantation (4, 15) and various studies on mice and humans with raised TMAO have revealed mechanistic and prognostic links between microbial TMAO production and both atherosclerosis and thrombosis, as well as chronic kidney disease and heart failure (4–6, 12, 13, 16–18). Importantly, recent studies aimed at blocking the metaorganismal TMAO pathway through multiple approaches have confirmed the inhibition of diet-dependent atherosclerosis in animal models, either by targeting the initial microbial formation of TMA from choline through use of a nonlethal small-molecule inhibitor (19), or by targeting the second step in the pathway, the major host gene responsible for converting microbe-generated TMA into TMAO, flavin monooxygenase 3 (20, 21). More recently, a family of potent and highly selective mechanism-based suicide substrate inhibitors were developed and shown to promote the irreversible inhibition of gut microbiota-dependent generation of TMA, suppression of host TMAO levels, and, in parallel, inhibition of platelet hyperresponsiveness and thrombosis potential in animal models (22). Moreover, microbial transplantation studies in germ-free mice with human commensals containing a functional (but not a deletion mutant) microbial *cutC* gene (responsible for choline→TMA transformation) (23) and genetic manipulation (both gain of function and loss of function) of host hepatic flavin monooxygenase 3 have been shown to modulate host TMAO levels, platelet responsiveness, and thrombosis potential *in vivo* (24). Thus, substantial and mounting evidence supports a direct contributory role of gut microbiota as a participant in CVD pathogenesis, and preclinical studies indicate that the therapeutic targeting of microbial contributors to the TMAO metaorganismal pathway may hold promise as a novel approach for the prevention or treatment of CVD. Accordingly, an improved understanding in humans of the microbial pathways involved in TMA/TMAO formation from distinct nutrients is an essential and necessary step in the development of targeted interventions to interrupt these processes.

L-Carnitine, a nutrient found primarily in red meat, was recently reported to be metabolized by gut microbiota to form TMA via the 2-component Rieske-type L-carnitine oxygenase CntA/B (25, 26), which requires molecular oxygen for activity. Although CntA/B may be responsible for some TMA formation by γ -proteobacteria intimately associated with the intestinal epithelium using oxygen that diffuses into the luminal content, because of its oxygen requirement, it is unlikely to be the primary physiologic source of L-carnitine→TMA activity in the mostly anoxic luminal intestinal environment. Furthermore, CntA/B-encoding genes have been identified only in facultative organisms and not in the many anaerobes that form the bulk of the gut microbiota (27). However, isotope tracer studies confirm that TMA and TMAO are sequentially made from orally ingested L-carnitine in both mice and humans, and L-carnitine supplementation has been shown to accelerate atherosclerosis development in murine models of the disease (6, 26). Parallel clinical studies show that omnivores have higher circulating concentrations of L-carnitine than vegans or vegetarians, and that elevated plasma concentrations of L-carnitine in subjects is associated with incident CVD risks (e.g., heart attack, stroke, and death) independent of traditional CVD risk factors, but only in the presence of elevated TMAO (6). Despite these

intriguing findings, it is unclear whether the mechanistic connection between L-carnitine ingestion and gut microbial production of TMA, and its downstream metabolite, TMAO, helps to explain the frequently observed association in epidemiologic studies of a dose-dependent relationship between red meat consumption and CVD risks (28–31). An improved understanding of oral L-carnitine metabolism in mammals and the potential involvement of gut microbiota-dependent processes is thus of considerable interest.

Upon more recent investigation of gut microbial metabolism of L-carnitine in mice, oral L-carnitine was discovered to not be directly converted into TMA via a simple 1-step process (i.e., a microbial L-carnitine TMA lyase activity; L-carnitine→TMA). Rather, the majority of orally ingested L-carnitine in mice produced a previously unappreciated intermediary metabolite, γ -butyrobetaine (γ BB), in a gut microbiota-dependent step that occurred at a site anatomically proximal to, and at a rate 1,000-fold higher than the rate of the formation of TMA (26). Historically, γ BB was discovered because of its role as the proximate endogenous biosynthetic intermediate in L-carnitine synthesis in mammals, a multistep pathway that generates L-carnitine from lysine (32–34). Dietary supplementation of mice with γ BB was shown to produce both TMA and TMAO, and to accelerate atherosclerosis, but only in the presence of gut microbiota (26). Thus, studies in mice have revealed a multistep metaorganismal pathway that is initiated by sequential gut microbiota-dependent conversions of oral L-carnitine into an atherogenic intermediate, γ BB, which is then converted into TMA, the immediate precursor for host hepatic transformation into TMAO (i.e., L-carnitine γ BB→TMA→TMAO). Whether γ BB is a major product of gut microbial catabolism of dietary L-carnitine in humans, and the relationship of chronic dietary patterns (e.g., omnivorous versus vegan/vegetarian) and L-carnitine exposure to γ BB metabolism in humans, are unclear. Herein, we explore the role of the gut microbiota in γ BB generation in humans, and the impact of preceding dietary history and oral L-carnitine supplementation on both γ BB generation and catabolism to TMA/TMAO in subjects. Finally, we also identify and characterize human fecal microbial community members that participate in the conversion of L-carnitine into TMA via the generation and catabolism of γ BB.

Results

Dietary L-carnitine produces γ BB in a gut microbiota-dependent manner in humans. In prior studies we showed gut microbiota-dependent TMA and TMAO generation following oral L-carnitine ingestion in omnivores, but virtually nonexistent TMA/TMAO formation from oral L-carnitine in long-standing (>1 year) vegans and vegetarians (6). However, we did not look for γ BB formation in those studies. Therefore, in initial pilot clinical studies (Figure 1), we first explored (in omnivores) whether γ BB could be formed from L-carnitine following oral ingestion of heavy isotope-labeled L-carnitine (d_3 -L-carnitine), and the potential participation of gut microbiota in that reaction. At the initial baseline visit, serial venous sampling performed after oral d_3 -L-carnitine challenge revealed rapid increases in plasma concentrations of d_3 -L-carnitine, and subsequent increases in d_3 - γ BB and d_3 -TMAO following a lag phase (Figure 1, A–C, filled circles). After the initial baseline challenge, subjects were placed on a week-long oral regimen of a

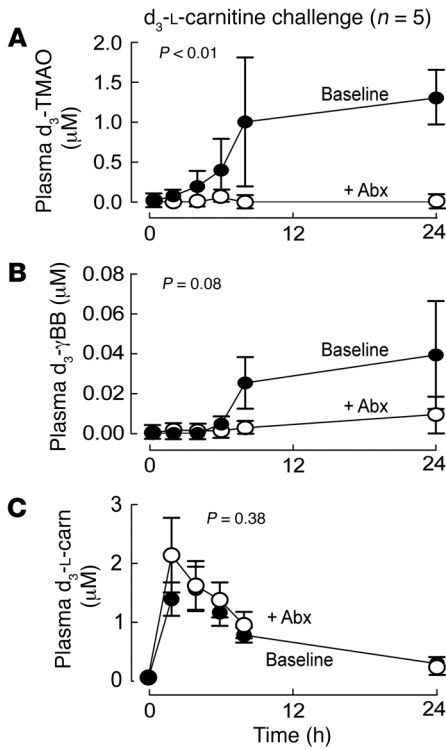

cocktail of poorly absorbed antibiotics previously shown to effectively suppress intestinal microbiota (6), and then the d_3 -L-carnitine challenge was repeated (Figure 1, open circles). Complete suppression of d_3 -TMAO and almost complete suppression of d_3 - γ BB formation were observed (Figure 1). These results are consistent with results observed in mice (26) and strongly support a role for gut microbiota in γ BB generation from dietary L-carnitine in humans. Finally, examination of plasma d_3 -L-carnitine concentrations before versus after exposure to the antibiotics cocktail also showed no differences (Figure 1C).

Ingestion of γ BB produces TMAO in a gut microbiota-dependent manner in humans. We next sought to test whether gut microbiota-formed γ BB could produce TMAO in humans. Heavy isotope-labeled γ BB (d_9 - γ BB) was synthesized and used to perform a similar oral “ γ BB challenge” of subjects ($n = 6$ omnivores). Following oral ingestion, rapid elevation in plasma concentrations of both d_9 - γ BB and d_9 -L-carnitine was observed, followed by d_9 -TMAO generation after a lag phase (Figure 2, A-C, filled circles). Interestingly, after a week-long suppression of the gut microbiota with oral broad-spectrum antibiotics cocktail, a rechallenge with oral

Figure 2. TMAO is a gut microbiota-dependent product of γ BB in humans. Subjects ($n = 6$) received oral d_9 - γ BB (250 mg; t_0), and then serial plasma aliquots were obtained at the noted time points (Baseline, filled circles). After a week-long regimen of oral broad-spectrum antibiotics to suppress the intestinal microbiota, the oral d_9 - γ BB challenge was repeated (+ Abx, open circles). Stable isotope dilution LC-MS/MS was used to quantify d_9 -TMAO (A), d_9 - γ BB (B), and d_9 -L-carnitine (C) in plasma collected from sequential venous blood draws at the noted times. Time points are mean \pm SEM plasma concentrations, and a zero-inflated linear mixed-effects model was used to compare subjects before and after antibiotic exposure.

Figure 1. γ BB and TMAO production from L-carnitine is a gut microbiota-dependent process in humans. Subjects ($n = 5$) ingested a capsule containing d_3 -L-carnitine (250 mg; t_0), after which serial plasma aliquots were obtained at the times shown (Baseline, filled circles). After a week-long regimen of oral broad-spectrum antibiotics to suppress the intestinal microbiota, the oral L-carnitine challenge was repeated (+ Abx, open circles). Stable isotope dilution LC-MS/MS was used to quantify d_3 -TMAO (A), d_3 - γ BB (B), and d_3 -L-carnitine (C) in plasma collected from sequential venous blood draws at the noted times. Time points are represented as mean \pm SEM plasma concentrations, and a zero-inflated linear mixed-effects model was used to compare subjects before and after antibiotic exposure.

d_9 - γ BB showed complete suppression of d_9 -TMAO formation in subjects, confirming gut microbiota-dependent conversion of γ BB into TMAO (Figure 2A, open circles). The production of d_9 -L-carnitine from oral d_9 - γ BB, however, was not suppressed with the oral antibiotics; moreover, on closer inspection, while the peak plasma concentration of d_9 - γ BB (2 hours) after oral ingestion significantly decreased by 8 hours ($P < 0.05$), the peak blood concentrations of d_9 -L-carnitine showed a relative plateau between 2 and 8 hours (Figure 2, B and C). These observations indicate that d_9 -L-carnitine production from oral d_9 - γ BB occurs via a mechanism that is not suppressed by antibiotics, and are consistent with expected results from the endogenous L-carnitine biosynthetic pathway (i.e., host conversion of γ BB to L-carnitine during carnitine biosynthesis) (32–34). Finally, examination of plasma d_9 - γ BB concentrations before versus after exposure to the antibiotics cocktail showed no differences (Figure 2B).

Omnivores generate significantly more TMAO than vegans/vegetarians from oral L-carnitine because of marked increase in gut microbial conversion of γ BB into TMA. We had previously reported that d_3 -L-carnitine challenge in omnivores showed significantly elevated d_3 -TMAO generation in comparison with vegans/vegetarians (6); we first recapitulated these findings and confirmed that omni-

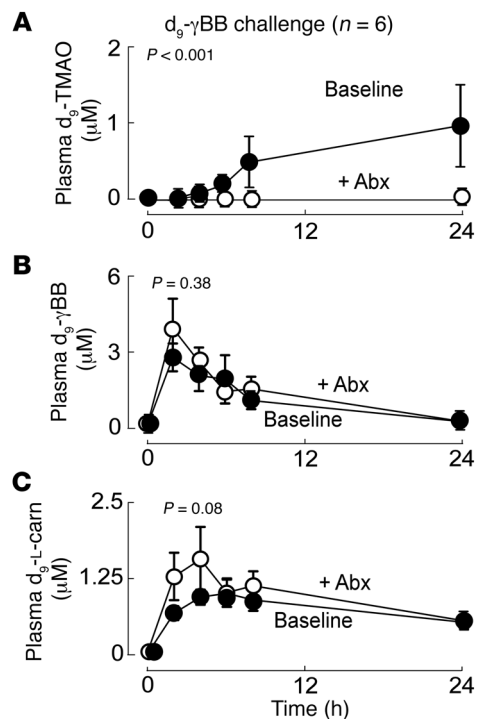

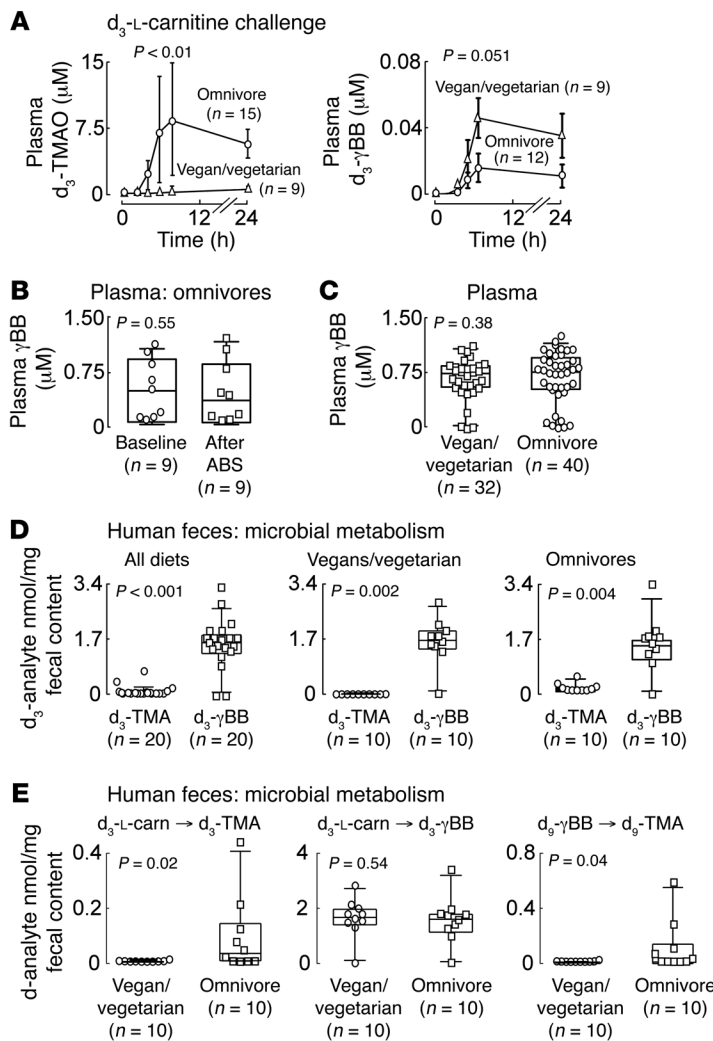

Figure 3. γ BB is a major gut microbiota metabolite of L-carnitine, and TMA formation from γ BB is influenced by dietary habits. (A) Plasma d_3 -TMAO and d_3 - γ BB concentrations in vegans/vegetarians (d_3 -TMAO, $n = 9$; d_3 - γ BB, $n = 9$) versus omnivores (d_3 -TMAO, $n = 15$; d_3 - γ BB, $n = 12$) participating in an oral d_3 -L-carnitine (250 mg) challenge. The left panel illustrates the marked differences in d_3 -TMAO generation previously reported in omnivores versus vegans/vegetarians. The right panel shows a small difference in plasma d_3 - γ BB concentration between omnivores and vegans/vegetarians. Data represent mean \pm SEM. A Mann-Whitney test was used to compare the AUCs between dietary groups. (B) Box-and-whisker plots of fasting plasma concentrations of γ BB from subjects ($n = 9$) before versus after 1 week of oral broad-spectrum antibiotics to suppress gut microbiota. Boxes represent the 25th, 50th, and 75th percentiles, and whiskers represent the 10th and 90th percentiles. Differences were assessed using a Wilcoxon matched-pairs test. (C) Fasting plasma concentrations of γ BB in vegans/vegetarians ($n = 32$) versus omnivores ($n = 40$). Boxes represent the 25th, 50th, and 75th percentiles, and whiskers represent the 10th and 90th percentiles. A Mann-Whitney test was used to assess differences between groups. (D) Baseline human fecal metabolite studies in vegans/vegetarians and omnivores ($n = 10$ each group). Fecal samples were incubated anaerobically with d_3 -L-carnitine, and d_3 -TMA and d_3 - γ BB were quantified by LC-MS/MS. Data are expressed as mean \pm SEM. A Mann-Whitney test was used to assess differences between groups. (E) Baseline human fecal metabolite studies in vegans/vegetarians ($n = 10$) versus omnivores ($n = 10$). Fecal samples were incubated with d_3 -L-carnitine or d_9 - γ BB as indicated. Metabolites were quantified by LC-MS/MS. Data are expressed as mean \pm SEM. A Mann-Whitney test was used to assess differences between groups.

vores ($n = 15$) have a much greater capacity to generate d_3 -TMAO from orally ingested d_3 -L-carnitine than vegans and vegetarians ($n = 9$) (Figure 3A, left panel). To determine the origins of this difference, we next explored each step in the multistep reaction. Notably, despite the dramatic difference in d_3 -TMAO production from oral d_3 -L-carnitine in omnivores versus vegans/vegetarians, the difference observed in the first step of that gut microbiota-mediated transformation, conversion of d_3 -L-carnitine to d_3 - γ BB, was not significant, and if anything showed a trend toward a lower conversion rate in the omnivores ($P = 0.051$; Figure 3A, right panel). Further, plasma concentrations of d_3 - γ BB observed following oral d_3 -L-carnitine challenge were approximately 20-fold lower relative to plasma d_3 -TMAO (Figure 3A, left vs. right panel). We next examined fasting endogenous plasma γ BB concentrations before versus after 1-week exposure to the oral antibiotics cocktail in subjects ($n = 9$ omnivores) and noted no significant differences ($P = 0.55$; Figure 3B). Moreover, while oral d_3 -L-carnitine ingestion produced d_3 - γ BB, comparison of endogenous fasting levels of γ BB in an expanded number of omnivores ($n = 40$) versus vegans/vegetarians ($n = 32$) failed to show any significant differences ($P = 0.38$; Figure 3C) and was notable also for the relatively low plasma levels of γ BB observed (in general, approximately 5- to 10-fold reduced compared with TMAO). Despite the expanded number of

subjects examined, no difference in endogenous plasma L-carnitine levels was observed between the vegans/vegetarians ($n = 32$) and the omnivores ($n = 40$) (mean \pm SEM: omnivores 31.3 ± 2.5 vs. vegans/vegetarians $39.1 \pm 4.3 \mu$ M; $P = 0.18$; Supplemental Figure 1; supplemental material available online with this article; <https://doi.org/10.1172/JCI94601DS1>).

Given that isotope tracer studies show γ BB is clearly formed following oral L-carnitine ingestion, and similarly, isotope-labeled γ BB was readily converted into isotope-labeled TMA/TMAO following oral ingestion, we hypothesized that low overall plasma concentrations of gut microbiota-produced γ BB in humans may be the result of microbial γ BB breakdown into TMA, predominantly occurring in the lower intestinal track (colon) distal to the absorption of most nutrients like L-carnitine and γ BB. To explore this possibility, we characterized human fecal polymicrobial metabolism under ex vivo anaerobic conditions using distinct heavy isotope-labeled substrates — i.e., synthetic d_3 -L-carnitine and d_9 - γ BB, allowing us to monitor d_3 -TMA (from carnitine) and d_9 -TMA (from γ BB) at the same time — from both omnivores ($n = 10$) and vegans/vegetarians ($n = 10$) (Figure 3, D and E). Multiple notable findings were observed. First, quantitatively, the generation of d_3 - γ BB from d_3 -L-carnitine by fecal microbiota under anaerobic culture was approximately 50-fold higher than d_3 -TMA formation in omnivore

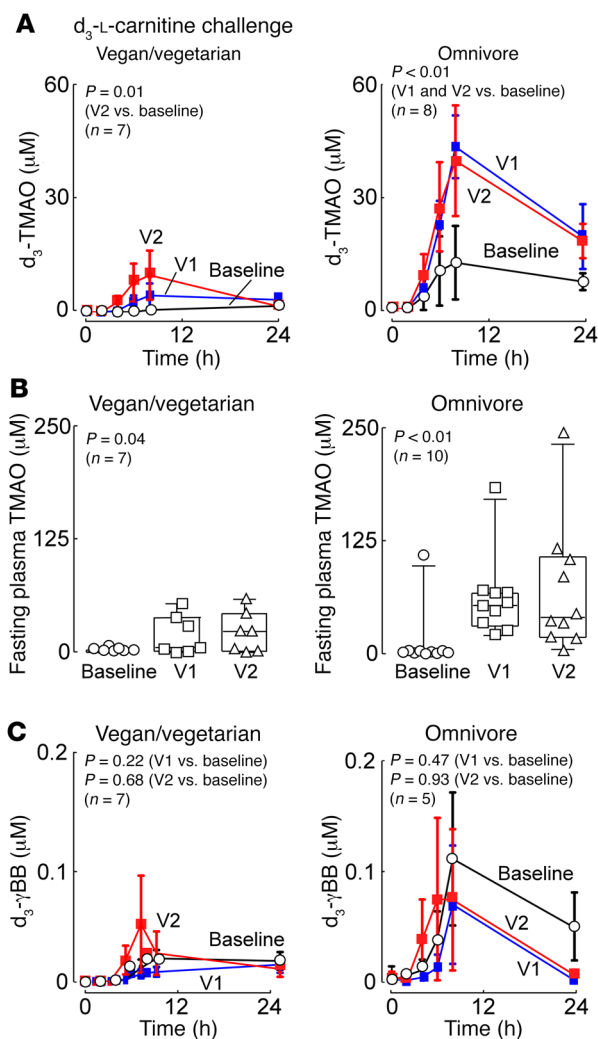

Figure 4. L-Carnitine supplementation enhances the synthetic capacity of gut microbiota to form TMAO. (A) Plasma d_3 -TMAO concentrations in sequential venous blood draws after oral d_3 -L-carnitine challenge in vegans ($n = 7$) and omnivores ($n = 8$) at baseline, visit 1 (V1, 1 month), and visit 2 (V2, 2–3 months). Data represent mean \pm SEM. A zero-inflated linear mixed-effects model reveals that plasma d_3 -TMAO is significantly higher after L-carnitine supplementation. (B) Plasma TMAO concentrations in vegans ($n = 7$) and omnivores ($n = 10$) at baseline and following daily L-carnitine supplementation at visit 1 (V1, 1 month), and visit 2 (V2, 2 months). Boxes represent the 25th, 50th, and 75th percentiles, and whiskers represent the 10th and 90th percentiles. A repeated-measures 1-way ANOVA test was used to assess differences between baseline visits. (C) Plasma d_3 - γBB concentrations in sequential venous blood draws after oral d_3 -L-carnitine challenge in vegans/vegetarians ($n = 7$) and omnivores ($n = 5$) at baseline, visit 1 (V1, 1 month), and visit 2 (V2, 2 months). Data represent mean \pm SEM. A zero-inflated linear mixed-effects model reveals that plasma d_3 - γBB production is not significantly higher after L-carnitine supplementation in vegans/vegetarians or omnivores.

Chronic dietary L-carnitine supplementation enhances gut microbiota-dependent generation of TMAO. The significant differences noted in overall metabolism of oral L-carnitine \rightarrow TMA/TMAO in omnivores and, to a lower extent, in vegans/vegetarians are a striking finding. We therefore sought to further explore the impact of chronic daily dietary L-carnitine exposure on these differences. Both vegans/vegetarians ($n = 7$) and omnivores ($n = 10$) gave consent and were instructed to continue with their typical diets but with the addition of supplemental L-carnitine (500 mg L-carnitine tartrate per day, provided in a Vegicap). Subjects were monitored at baseline, at 1 month, and after 2–3 months of continuous daily supplemental L-carnitine ingestion by examination of the rate of plasma appearance of both d_3 -TMAO (Figure 4A) and d_3 - γBB (Figure 4C) following oral d_3 -L-carnitine challenge. In addition, fasting plasma levels of endogenous TMAO (Figure 4B) and γBB (Supplemental Figure 2) were monitored. At baseline, vegans/vegetarians showed minimal synthetic capacity to produce d_3 -TMAO following ingestion of d_3 -L-carnitine, whereas omnivores readily generated d_3 -TMAO (Figure 4A). After 1 month of daily L-carnitine supplementation, enhancement in the formation of d_3 -TMAO following d_3 -L-carnitine ingestion was observed in vegans/vegetarians and omnivores alike (Figure 4A). Continuation of daily L-carnitine supplementation for at least an additional month resulted in no further increase in d_3 -L-carnitine \rightarrow d_3 -TMAO transformation in omnivores, but continued to increase d_3 -TMAO generation in vegans/vegetarians following oral d_3 -L-carnitine challenge (Figure 4A). Examination of individual plots of plasma d_3 -TMAO production from oral d_3 -L-carnitine challenges among vegans/vegetarians ($n = 7$) demonstrated that the mean increase observed was driven by only a subset ($n = 3$) of subjects, with over half ($n = 4$) of the vegans/vegetarians demonstrating essentially no metabolic capacity to convert oral d_3 -L-carnitine into d_3 -TMAO even after months of L-carnitine supplementation (Supplemental Figure 3). Fasting plasma concentrations of TMAO in both omnivores and vegans/vegetarians increased upon chronic (1 month) L-carnitine supplementation, but did not significantly further increase with another month of supplementation (Figure 4B). Interestingly, in both vegans/vegetarians and omnivores, chronic L-carnitine supplementation

and vegan/vegetarian alike ($P < 0.001$; Figure 3D). These results indicate that γBB is a major gut microbial metabolite formed from oral L-carnitine in humans (for both omnivores and vegans/vegetarians). Second, fecal microbiota from omnivores (vs. vegans/vegetarians) showed a significantly enhanced ($P = 0.02$) enzymatic capacity to produce TMA from L-carnitine (Figure 3E, left). And yet, third, no difference was observed in the fecal transformation of L-carnitine to γBB in vegans/vegetarians compared with omnivores ($P = 0.54$; Figure 3E, middle). Finally, results of the fecal polymicrobial culture studies indicate that the marked increased generation of TMA (and TMAO) from oral L-carnitine in omnivores versus vegans/vegetarians appears to be due to significantly (up to 10-fold) greater gut microbial conversion of γBB to TMA in omnivores relative to vegans/vegetarians (i.e., chronic exposure to L-carnitine in an omnivorous diet is associated with an increase in microbial capacity to catalyze the transformation of γBB to TMA; $P = 0.04$; Figure 3E). Collectively, these data suggest that in the multistep metabolism of dietary L-carnitine into TMAO (i.e., L-carnitine \rightarrow γBB \rightarrow TMA \rightarrow TMAO), gut microbial metabolism of L-carnitine \rightarrow γBB occurs rapidly in omnivore and vegan/vegetarian alike, and the latter microbial transformation of γBB to TMA is the one markedly enhanced in omnivores over vegans/vegetarians (i.e., influenced by chronic dietary habits; Figure 3E).

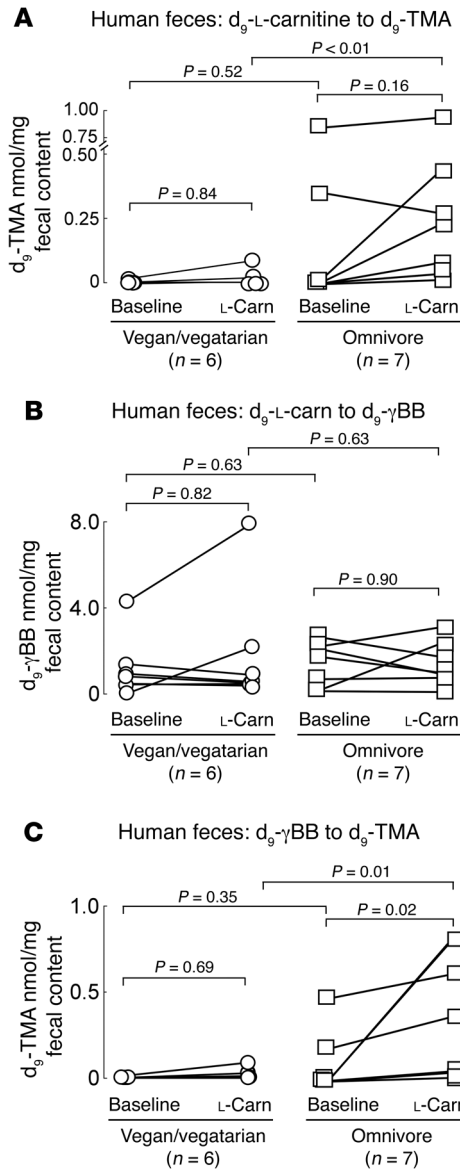

Figure 5. L-Carnitine supplementation does not enhance the synthetic capacity of gut microbiota to produce γ BB from L-carnitine, but does enhance gut microbiota-dependent transformation of γ BB into TMA.

At baseline and after L-carnitine supplementation (L-Carn; 2–3 months), human fecal metabolite studies ($n = 6$ omnivores and $n = 7$ vegans/vegetarians) in the conversion of d_9 -L-carn to d_9 -TMA (A), d_9 -L-carn to γ BB (B), or d_9 - γ BB to d_9 -TMA (C). Fecal samples were incubated with either d_9 -L-carnitine or d_9 - γ BB as described in Methods, and d_9 -TMA and d_9 - γ BB were quantified by LC-MS/MS. A Wilcoxon matched-pairs test was used to assess for differences between groups.

L-carnitine supplementation induced no differences in fecal transformation of the first step of the L-carnitine \rightarrow γ BB \rightarrow TMA/TMAO metaorganismal pathway in either omnivores or vegans/vegetarians, dietary L-carnitine provision induced enhanced fecal microbial transformation of the second microbial step in the overall pathway (i.e., d_9 - γ BB \rightarrow d_9 -TMA) in omnivores ($P = 0.02$), but not vegans/vegetarians ($P = 0.69$) (Figure 5C).

Multiple organisms are involved in the gut microbial production of TMA from L-carnitine. Since L-carnitine catabolism is mediated by microbial enzymes, we sought to identify the organisms involved in anaerobic L-carnitine degradation in fecal samples from a healthy omnivore donor (Figure 6A). In previous studies, single gastrointestinal microbial strains were reported to be unable to catabolize L-carnitine into TMA (35). We therefore hypothesized that multiple organisms are needed for catabolism of L-carnitine to TMA presumably with γ BB as an intermediate. Therefore, we isolated not only single microbial colonies from feces but also subcommunities of 2–3 and 4–5 colonies, and tested the ability of each single isolate or subcommunity to produce TMA from L-carnitine. Though no single isolate produced TMA, 2 subcommunities out of 768 did produce TMA, and 1 of those subcommunities was further fractionated using a similar strategy as before (i.e., single, 2–3, and 4–5 colonies; Figure 6A). A noticeable enrichment in the number of TMA-producing subcommunities was observed, but again no individual isolate could perform the L-carnitine \rightarrow TMA transformation. The subcommunity producing the most TMA was spread and plated once more, and 100 colonies of the community were preliminarily identified by proteomics analyses using matrix-assisted laser desorption/ionization time-of-flight (MALDI-TOF) mass spectrometry (36). The colonies were pooled based on best-match organism into 5 species pools (SP1 through SP5; Supplemental Table 1). Individual pools and combinations were evaluated for L-carnitine \rightarrow TMA activity using a fractional factorial design (Figure 6B). Absence of either SP2 or, to a lesser extent, SP5 abolished the L-carnitine \rightarrow TMA activity, whereas maximum production of TMA was attained only when both SP2 and SP5 were present. Each species pool (SP2 and SP5) was further subfractionated into individual colonies, and all members were evaluated alone or in combination with the members of the other pool. Only the combination of SP5-56 or SP5-62 with SP2-71 yielded maximum TMA production (Figure 6C). These data confirm our hypothesis and demonstrate that at least 2 different organisms are required for the anaerobic catabolism of L-carnitine to TMA. Both SP5-56 and SP5-62 were identified as isolates of *Eggerthella lenta* by 16S-rRNA gene sequencing. Further characterization of SP2-71 indicated that it was not a single strain, but a combination of 4 microbes (Supple-

induced no significant differences in the rates of d_3 - γ BB formed following oral d_3 -L-carnitine challenge or in fasting plasma γ BB concentrations (Figure 4C and Supplemental Figure 2).

We next sought to biochemically characterize microbial transformation activities in feces of subjects before versus after L-carnitine supplementation. A subset of subjects ($n = 7$ omnivores, $n = 6$ vegans/vegetarians) consented to provide feces at both baseline and the end of the study following at least 2 months of L-carnitine supplementation for analyses (Figure 5). At baseline, comparisons between omnivores and vegans/vegetarians showed no significant differences in any of the fecal microbial metabolic transformations monitored (d_9 -L-carnitine \rightarrow d_9 -TMA, d_9 -L-carnitine \rightarrow d_9 - γ BB, and d_9 - γ BB \rightarrow d_9 -TMA; $P = 0.52$, $P = 0.63$, $P = 0.35$, respectively) (Figure 5, A–C). However, following chronic L-carnitine supplementation, fecal samples recovered from omnivores showed significantly enhanced generation of d_9 -TMA from either d_9 -L-carnitine or d_9 - γ BB relative to vegan/vegetarian fecal samples ($P < 0.01$ and $P = 0.01$, respectively; Figure 5, A and C). Further, while dietary

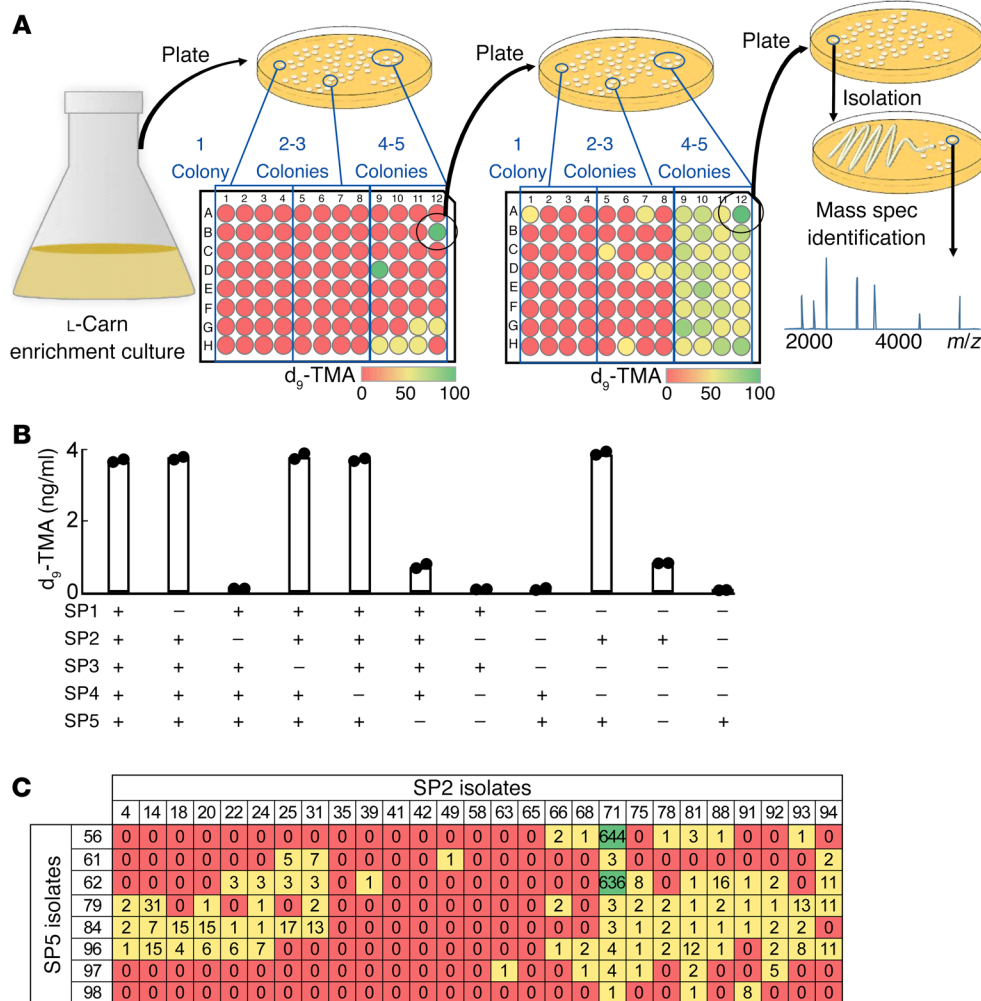

Figure 6. L-Carnitine catabolism to TMA involves multiple microorganisms. (A) L-Carnitine-enriched fecal communities were plated on solid media. Single microbial colonies and subcommunities of up to 3 and 4+ colonies were picked and tested for their L-carnitine→TMA activity. The top producing community was refractonated to select the highest TMA-producing subcommunity. (B) Species pools (SP1 through SP5) were evaluated alone or in combination for L-carnitine→TMA activity in $n = 2$ replicate values. Data are expressed as the mean. (C) Combinations of individual members of SP2 and SP5 were evaluated for TMA production. Concentrations of d_9 -TMA were determined by stable isotope dilution LC-MS/MS.

mental Figure 4A). Of the 4 microbes, 1 had not been reported at the time of isolation, but showed 99% 16S-rRNA gene sequence identity (Supplemental Figure 4B) with an organism recently isolated by others and classified as *Emergencia timonensis* (37). Interestingly, *E. timonensis* (SP2-71.3) produced TMA in the absence of molecular oxygen, suggesting a novel microbial pathway for L-carnitine catabolism independent of the CntA/B oxygenase (25, 26).

Human commensal utilization of L-carnitine is decoupled from TMA production and generates γ BB as intermediate. We next studied which of the isolated human commensals were necessary and sufficient to metabolize L-carnitine to TMA. Each of the microbes contained in species pool SP2-71 was evaluated alone or in combination with *E. lenta* (species pool SP5-62; Figure 7A). L-Carnitine was always consumed in the presence of *E. lenta* (SP5-62), regardless of whether other microbes were present. However, TMA production was decoupled from L-carnitine utilization and was only produced when both *E. lenta* (SP5-62) and SP2-71.3 (or the entire SP2-71 pool) were present, which suggests that *E. lenta* (SP5-62) is associated with L-carnitine consumption and SP2-71.3 is responsible for TMA production (Figure 7A). We mined the genome of *E. lenta* (SP5-62) for genes likely to be associated with L-carnitine utilization and noticed genes of the *caiTABCD E* gene operon that encode for a crotonobetaine reductase, L-carnitine-CoA trans-

ferase, and L-carnitine-CoA ligase, among other genes (Figure 7B). Reasoning that the enzymes encoded by these genes could be responsible for the utilization of L-carnitine and its conversion to γ BB (Figure 7C), we used comparative genomics tools to identify 3 other organisms that contain the *caiTABCD E* gene operon (Supplemental Figure 5), and assessed their ability to consume L-carnitine and produce γ BB (Figure 8). Although none of the 3 microbes, *Escherichia fergusonii*, *Edwardsiella tarda*, and *Proteus penneri*, produced TMA, all 3 consumed L-carnitine while producing γ BB, suggesting that the utilization of L-carnitine is associated with the presence of the *caiTABCD E* genes. The combination of any of the 3 microbes with *E. timonensis* (SP2-71.3) led to anaerobic, oxygen-independent, TMA production from L-carnitine and consumption of γ BB (Figure 8). The *E. timonensis* type strain SN18 (37) performed very similarly to *E. timonensis* SP2-71.3 in this study (data not shown).

During L-carnitine catabolism by human gut commensals and fecal polymicrobial anaerobic cultures, γ BB accumulates as an intermediate before it is anaerobically converted to TMA. We then determined the kinetics of consumption of L-carnitine and production of γ BB and TMA by *P. penneri* (ATCC 35198), one of the human commensals shown to produce γ BB, alone or in combination with *E. timonensis* (SP2-71.3) (Figure 9A). Addition of L-carnitine to an

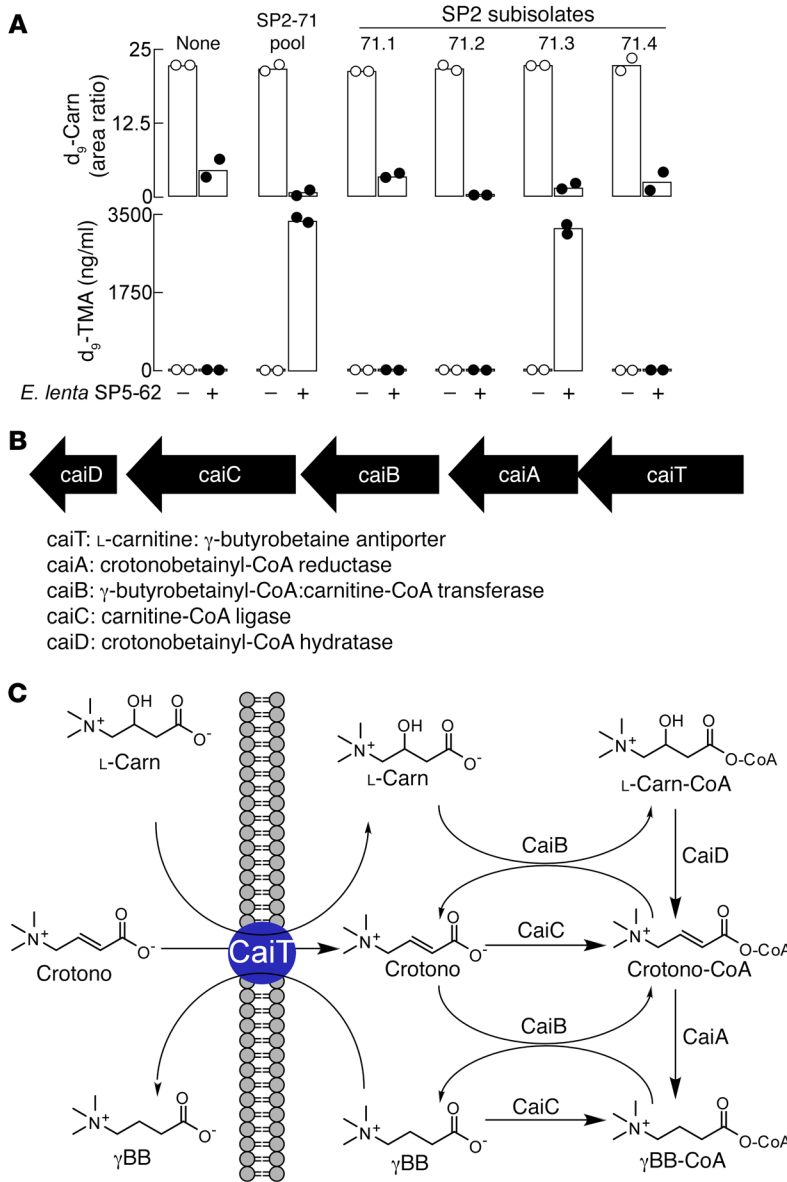

Figure 7. Anaerobic microbial L-carnitine consumption is associated with the presence of the microbial *caiTABCDE* genes. (A) Individual SP2-71 microbes were evaluated alone or in combination with *E. lenta* SP5-62 for L-carnitine→TMA activity. Data are expressed as the mean of the d_5 -L-carnitine peak ratio and d_5 -TMA concentration in $n = 2$ replicate values. (B) *E. lenta* genome mining revealed the presence of the *caiTABCDE* gene operon. Data are expressed as the mean. (C) L-Carnitine→ γ BB pathway involving enzymes encoded by the *caiTABCDE* gene operon. Crotono, crotonobetaine.

tions that occur in the presence of gastrointestinal polymicrobial communities, the anaerobic metabolism of L-carnitine by fecal communities from 12 human healthy donors (all omnivores) was studied. For illustrative purposes, biochemical transformations characteristic of omnivores following carnitine supplementation (subjects 1 and 7) and vegans or vegetarians (i.e., little TMA generation: subjects 10 and 12) are shown in Figure 9B, while data from all 12 subjects are shown in Supplemental Figure 6. The communities of all 12 subjects converted the majority of L-carnitine to γ BB within 12 hours of incubation, although not all subjects produced TMA from γ BB by 32 hours (Figure 9B). Moreover, γ BB formation (before TMA generation) was quantitatively associated with L-carnitine consumption, and when produced, TMA formation was quantitatively associated with γ BB consumption. Thus, the demonstrated kinetics of generation and decay of the metabolites monitored followed the anticipated precursor→product relationships, and were entirely consistent with the initial microbial conversion of L-carnitine to γ BB, followed by transformation of γ BB to TMA, reaction kinetics akin to the dynamics of L-carnitine catabolism observed with the human commensals *P. penneri* and *E. timonensis*.

anaerobic culture of *P. penneri* alone (in M9 minimal medium) resulted in quantitative transformation of L-carnitine to γ BB within 4 hours with no TMA production. *E. timonensis* alone did not consume L-carnitine or produce TMA from L-carnitine. However, the combination of *P. penneri* and *E. timonensis* led to a transient accumulation of γ BB that was subsequently consumed with concomitant production of TMA (Figure 9A, top). When M9 minimal medium was instead supplemented with γ BB, *P. penneri* alone was unable to consume γ BB or produce TMA, whereas only *E. timonensis* was sufficient to produce TMA from γ BB in the presence or absence of *P. penneri* (Figure 9A, bottom). To our knowledge, this is the first report of a single microbial strain capable of producing TMA from one of the metabolites of the L-carnitine pathway under anaerobic conditions. Moreover, kinetic analyses reveal that the production of γ BB precedes production of TMA, consistent with γ BB being needed to induce the γ BB→TMA phenotype.

To assess whether the transient buildup of γ BB in vitro with only 2 microbial strains represents the biochemical transforma-

Discussion

Historically, γ BB is known for its role as the last biosynthetic intermediate in a series of endogenous reactions used to synthesize L-carnitine from lysine (38). Given the important role of L-carnitine in fatty acid transport and metabolism, early studies of γ BB (sometimes coined “pre-L-carnitine”) focused on its ability to form L-carnitine and facilitate fatty acid transport (32, 39). Early studies recognized that mammals: (i) lack the capacity to catabolize L-carnitine; (ii) gut microbial bacteria have the capacity to degrade L-carnitine into numerous products; and (iii) γ BB may be a gut microbial product of L-carnitine after, in one study, trace concentrations of radiolabeled γ BB were discovered in feces following oral ingestion of radiolabeled L-carnitine (39–41).

However, gut microbial formation and catabolism of γ BB during oral L-carnitine metabolism in omnivores versus vegans/vegetarians, the human commensals that can utilize γ BB as a nutrient, and the relationship of this metabolite to the metaorganismal TMAO pathway and CVD had not yet been explored.

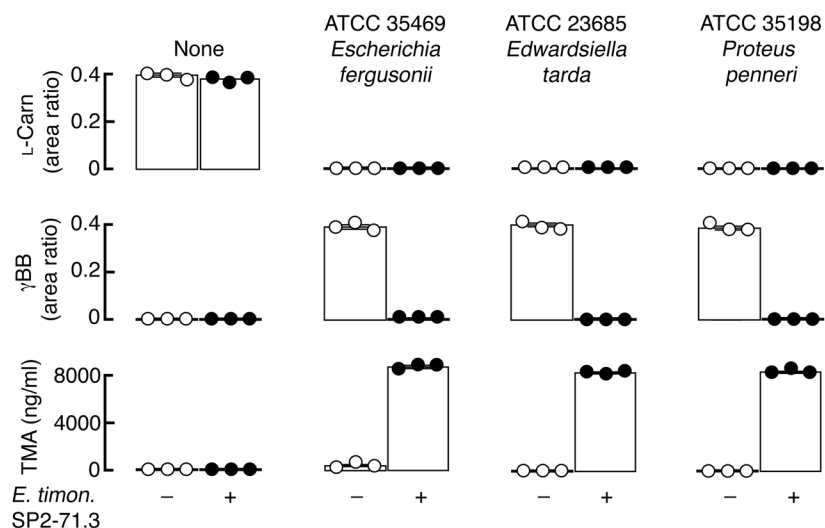

Figure 8. *CaiTABCDE* gene-expressing microbes consume L-carnitine, but only make TMA in the presence of *E. timonensis*. Concentrations of L-carnitine and TMA were determined by stable isotope dilution LC-MS/MS in $n = 3$ replicate values. Data are expressed as mean \pm SEM.

An overview of dietary L-carnitine metabolism in humans, its relationship to both γ BB and CVD risks, and the impact of preceding dietary pattern (omnivorous versus vegan/vegetarian), as well as chronic L-carnitine supplementation, as revealed by the present studies, are summarized in the scheme shown in Figure 10. Also shown are the adverse clinical outcomes associated with elevated systemic TMAO levels in subjects, and enhanced cardiometabolic phenotypes observed with elevated TMAO levels in animal models (4–6, 12, 13, 16–18).

In addition to being a product of endogenous synthesis during L-carnitine generation, the present studies reveal that γ BB is a major product of gut microbiota-dependent catabolism of orally ingested L-carnitine in humans, and is an intermediate in TMAO formation from L-carnitine. Moreover, the present studies reveal that the overall conversion of orally ingested L-carnitine to TMAO is a complex multistep process requiring an initial gut microbial L-carnitine \rightarrow γ BB conversion, followed by a second γ BB \rightarrow TMA transformation. Further, each step is carried out by different members of the gut microbial community. In addition, chronic dietary exposure to L-carnitine results in induction of enhanced gut microbiota catabolism of L-carnitine principally mediated by the second step — γ BB catabolism producing TMA — resulting in greater TMAO generation in the omnivorous versus the vegan/vegetarian host (Figure 10). Importantly, γ BB \rightarrow TMA occurs in an anaerobic environment, which suggests that it is catalyzed not by the CntA/B oxygenase, but rather by a novel oxygen-independent enzymatic pathway for the conversion of metabolites of the L-carnitine pathway to TMA. It is also notable that the microbial γ BB \rightarrow TMA activity was induced even in some vegans/vegetarians despite continuation of a vegan/vegetarian diet, with L-carnitine supplementation. Despite this, the TMAO production capacity still appeared greater in omnivores compared with vegans/vegetarians. Remarkably, among the vegans/vegetarians examined, roughly half (4 of 7) demonstrated little or no capacity to produce more TMA or TMAO from L-carnitine, despite 2 or more months of the daily L-carnitine supplementation. Vegans/vegetarians unable to produce TMAO from L-carnitine had no antibiotic or probiotic exposure (like all subjects enrolled), were recruited from the same geographic region as the other subjects, and were appar-

ently healthy with no significant known comorbidities. Given the low proportion of culturable human fecal commensals identified in the subculture experiments that were capable of promoting the second microbial transformation reaction (γ BB \rightarrow TMA), we speculate that the vegans/vegetarians unable to produce TMA and thus TMAO from L-carnitine simply lack microbial community members, like *E. timonensis*, that possess the polypeptide(s) required to promote the γ BB \rightarrow TMA metabolic transformation.

While the present studies reveal important aspects of L-carnitine metabolism in humans and illuminate the intermediary involvement of γ BB in TMAO generation from dietary L-carnitine, multiple important questions remain before we can exploit this newfound knowledge to develop therapeutic interventions that target this pathway. In this study, human gut commensals that can metabolize L-carnitine into γ BB, and γ BB into TMA, are reported for the first time to our knowledge. Although examination of fecal polymicrobial cultures indicates both the presence and dietary induction of fecal microbial γ BB \rightarrow TMA transforming activity, the microbial gene(s) encoding this enzyme activity, an important potential therapeutic target, remain unknown. Early studies with the bacterial isolate *Acinetobacter calcoaceticus* have reported a link between γ BB and TMA production (42). We also recently reported association studies between specific cecal microbial taxa and plasma γ BB concentrations in mice (26). Further characterization of the human commensals capable of both reactions (L-carnitine \rightarrow γ BB and γ BB \rightarrow TMA), and discovery of the enzyme(s) responsible for TMA production, are of interest — particularly since this latter microbial step in the overall pathway appears to be the major one induced during chronic dietary red meat exposure (or directly with L-carnitine supplementation) in an omnivorous diet (Figure 10). While speculative, it is a logical extension that induction of the γ BB \rightarrow TMA transformation activity may play a role in the heightened CVD risks observed in omnivores versus vegans/vegetarians, or subjects who eat diets rich in red meat. This hypothesis merits further study.

One of the more surprising findings of the present studies was the relatively small amount of d_3 - γ BB found in plasma compared with d_3 -TMAO after d_3 -L-carnitine challenge, especially after ex vivo fecal studies showed that γ BB is a major metabolite

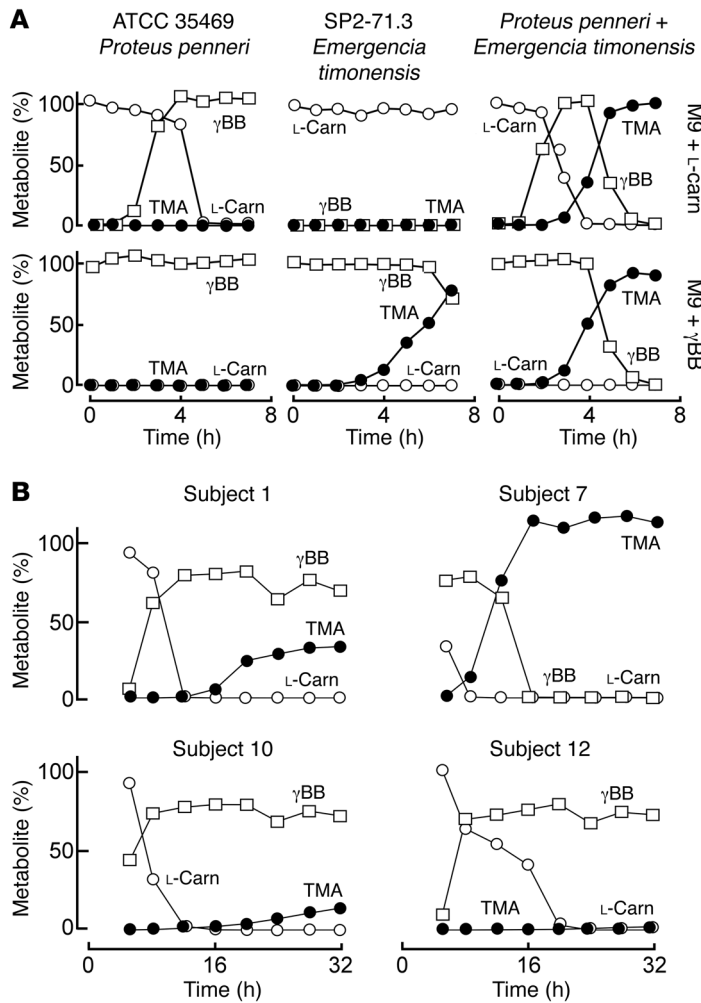

Figure 9. Anaerobic microbial L-carnitine catabolism generates γ BB as an intermediate. (A) Kinetic changes of L-carnitine, γ BB, and TMA were determined in cultures of *P. penneri* alone or in combination with *E. timonensis*, SP2-71.3, supplemented with L-carnitine (top panel) or γ BB (bottom panel). Concentrations were determined in $n = 2$ replicate values. Data are expressed as the mean. (B) Selected human fecal communities from 4 different donors were studied for their L-carnitine \rightarrow γ BB \rightarrow TMA activity sampling ($n = 1$) every 4 hours for 32 hours. Concentrations of L-carnitine, γ BB, and TMA were determined by stable isotope dilution LC-MS/MS. All human subjects are displayed in Supplemental Figure 6.

and mortality risks across multiple patient populations and geographic areas (45–47). In fact, in one meta-analysis, each 10- μ M increase in TMAO was reported to be associated with an absolute 7.6% increased risk of all-cause mortality (45). It is also worth noting that animal model studies have illustrated a mechanistic contribution of microbial TMA and TMAO generation to enhanced development of atherosclerosis, platelet reactivity and thrombosis, and both impairment in renal function and fibrosis, as well as adverse ventricular remodeling and heart failure (refs. 4–6, 13, 16, 17, and Figure 10). From a public health standpoint, the impact of TMAO elevation during L-carnitine supplementation is unknown, but both vegan/vegetarian and omnivore on average showed a greater than 10- μ M increase in circulating TMAO levels with L-carnitine supplementation. Owing to the critical physiologic role of L-carnitine in cellular fatty acid metabolism, there has been a belief that oral consumption of L-carnitine is beneficial in energy expenditure, when, in fact, there is equivocal evidence for enhancement in healthy individuals (48–54). Yet use of L-carnitine by the nutritional supplement industry, particularly in some energy drinks, and to a lesser extent in some protein supplements, is generally regarded as safe. Notably, the dose of L-carnitine supplement that subjects received in this study was well within the range of normal dietary exposure, and is comparable to the amount of L-carnitine in a single can of some energy drinks marketed presently, as well as the content of L-carnitine in a typical restaurant-portion steak dinner (55, 56). The present studies demonstrate that frequent dietary L-carnitine, even among some vegans/vegetarians, induces the gut microbiota’s capacity to produce TMAO, and may thus foster proatherogenic processes (6). It is also relevant that in recent studies, we have shown that TMAO directly interacts with human platelets (both isolated and in whole blood), altering stimulus-dependent calcium signaling and promoting platelet hyperresponsiveness (4). Moreover, elevated systemic concentrations of TMAO enhanced thrombosis potential in vivo in animal models (4), and in recent clinical intervention studies, elevation in plasma TMAO induced with dietary choline supplementation altered platelet hyperresponsiveness in subjects (omnivores and vegans/vegetarians alike), as monitored by platelet aggregometry (17). The present studies show that chronic exposure to dietary L-carnitine similarly elevates TMAO concentrations. Whether parallel alteration in platelet responsiveness and long-term thrombosis risk occurs in subjects remains to be determined, but as noted above, elevated serum levels of carnitine are associated with enhanced risks of major adverse cardiovascular events (6).

of L-carnitine produced by human fecal polymicrobial cultures (43). Moreover, in mice we observed that chronic L-carnitine supplementation resulted in markedly elevated plasma γ BB levels (more so than L-carnitine or TMAO), and it was the first step of the overall gut microbial catabolic pathway (i.e., L-carnitine \rightarrow γ BB) that was induced in mice following chronic L-carnitine dietary exposure (26). However, the present studies in humans revealed that γ BB plasma levels do not increase significantly following chronic dietary exposure to supplemental L-carnitine, and no differences were observed in plasma levels of omnivores versus vegans/vegetarians. While the origins of the observed differences between mice and humans with respect to the L-carnitine \rightarrow γ BB \rightarrow TMA \rightarrow TMAO pathway are not clear, the fact that the second reaction in the conversion of L-carnitine into TMA (i.e., γ BB \rightarrow TMA) showed marked induction with dietary exposure in subjects likely plays a major role in the observed differences. Still to be determined is whether this gain of function is the result of changes in the structure or the function of the gastrointestinal microbial community. That there exist interspecies differences in biosynthetic pathways mediated by gut microbiota metabolism between mice and humans is consistent with numerous other examples of how gut microbiomes of mammalian species can differ (44).

Multiple recent meta-analyses have confirmed that plasma TMAO levels are dose-dependently associated with incident CVD

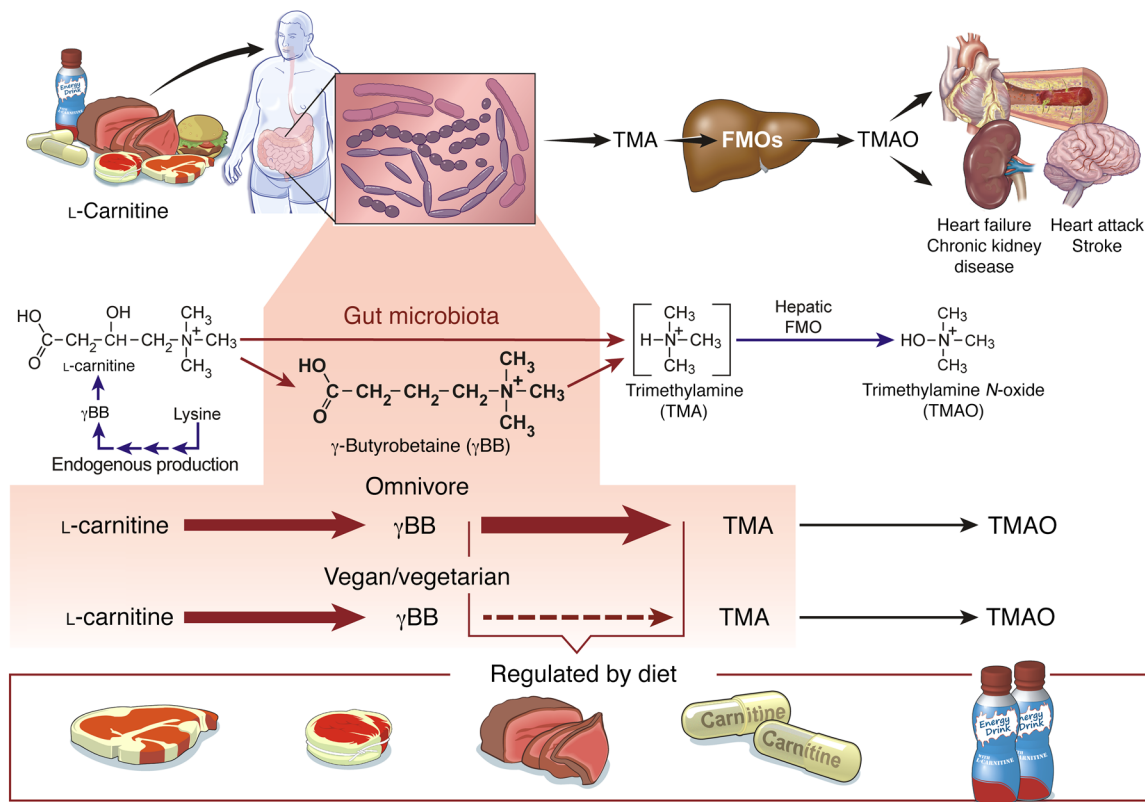

Figure 10. Scheme of L-carnitine and γ BB metabolism in humans, links to gut microbial TMAO generation, and adverse cardiometabolic phenotypes. FMO, flavin-containing monooxygenase.

There remain some limitations to these studies. First, while antibiotic suppression is used to invoke a role for gut microbiota in the generation of the metabolite(s) monitored, antibiotics can also have direct effects on the host, altering normal metabolism (57, 58). Secondly, we did not have access to hepatic tissues in subjects, and cannot definitely rule out that there may be some dietary influence on flavin monooxygenase-dependent conversion of TMA to TMAO. Similarly, we did not explore whether dietary patterns differentially influence renal excretion of TMAO. Finally, the studies used relatively small numbers of individuals, and thus do not allow for investigation of significant differences in sex, race, or other subgroups. We are thus cautious about the generalizability of these studies to greater populations.

In summary, the present studies add to our understanding of gut microbiota involvement in nutrient metabolism relevant to red meat ingestion, a Western diet, and CVD risks. Our studies reveal that L-carnitine \rightarrow TMA is a multistep biochemical transformation mediated by multiple members of the gut microbial community via formation of an intermediate, γ BB, previously shown to be proatherogenic in animal models. These studies also indicate that daily consumption of L-carnitine, even while maintaining a vegan/vegetarian diet, can induce the gut microbiota-dependent γ BB \rightarrow TMA transformation, resulting in heightened formation of the atherogenic and prothrombotic metabolite TMAO. Finally, our studies provide important insights for efforts aimed at development of therapeutic interventions designed to inhibit dietary L-carnitine conversion into TMAO in humans.

Methods

Materials and general procedures. Human fasting lipid profiles and blood chemistries were measured using the Abbott ARCHITECT platform, model ci8200 (Abbott Diagnostics). Human subject gut microbiota suppression was achieved using a cocktail of oral poorly absorbed antibiotics as previously described (7). All stable isotope-labeled compounds used in the present studies were synthesized as described below. Plasma levels of endogenous and stable isotope-labeled L-carnitine, γ BB, and TMAO were determined by stable isotope dilution liquid chromatography–tandem mass spectrometry (LC-MS/MS) in positive multiple reaction monitoring (MRM) mode as previously described (6) using a Shimadzu 8050 triple quadrupole mass spectrometer with ultra-HPLC interface. Laboratory personnel performing MS analyses were blinded to sample group allocation and clinical data during analysis.

Research subjects. Healthy subjects were enrolled in a study named CARNIVAL (NCT01731236; <https://clinicaltrials.gov/ct2/show/NCT01731236>), which studies gut microbial metabolism of L-carnitine in subjects. Subjects were divided into vegan/vegetarian or omnivore groups based on extensive dietary questioning. To be defined as vegan/vegetarian, the subject gave a history of no meat consumption for the preceding 1-year period. Baseline plasma and/or feces samples were collected. A subset of subjects were given oral heavy isotope-labeled L-carnitine challenge testing as outlined below. Subjects performed the oral L-carnitine challenge test by consuming 250 mg of synthetic d_3 (methyl)-L-carnitine within a capsule (Vegicap, Catalent), followed by serial venous plasma draws collected in EDTA vacutainer tubes for

d_3 -L-carnitine metabolite quantification. Other subjects underwent a similar γ BB challenge test following oral administration of 250 mg of synthetic d_9 (methyl)- γ BB (also provided in Vegicap). Dietary habits of subjects were determined using a questionnaire similar to that conducted by the Atherosclerotic Risk in Community (ARIC) study (59). Subjects were excluded from L-carnitine or γ BB challenge testing if they were pregnant, had chronic illness (including a known history of heart failure, renal failure, pulmonary disease, gastrointestinal disorders, or hematologic diseases), had an active infection, received antibiotics within 2 months of study enrollment, used any over-the-counter or prescription probiotic or bowel-cleansing preparation within the past 2 months, ingested yogurt within the past 7 days, or had undergone bariatric or other intestinal (e.g., bowel resection/reconstruction) surgery. Subjects were recruited by self-selection at Cleveland Clinic. Neither subject participants nor those administering the intervention were blinded, though investigators performing MS analyses were blinded to sample identities other than sample identification codes. Where indicated, a subset of subjects were instructed to continue with their current diet but, in addition, were placed on oral L-carnitine supplement (500 mg L-carnitine tartrate daily) and rechallenged in follow-up visits at 1 month and 2–3 months from baseline. All but 1 omnivorous subject completed all 3 visits. Some subjects had only baseline and 24-hour measurements taken of d_3 -L-carnitine metabolites. Others underwent the entire L-carnitine or γ BB challenge (i.e., had samples drawn 0, 2, 4, 6, 8, and 24 hours after ingestion of the indicated heavy isotope compound). If subjects experienced side effects of the noted treatment including, but not limited to, nausea, vomiting, diarrhea, or fever, they were instructed to stop treatment. If subjects failed to comply or did not tolerate the intervention, they were removed from the relevant analysis. Subjects were paid for each complete participated visit. A total of 35 subjects were enrolled in the heavy-isotopologue challenge studies, which included either d_9 - γ BB or d_3 -L-carnitine. Subjects were stratified by diet into $n = 11$ vegans/vegetarians and $n = 24$ omnivorous subjects. One enrolled vegan/vegetarian subject was later excluded as a result of reported nausea and a low BMI, 1 omnivorous subject declined the challenge after being enrolled and giving consent, 3 subjects enrolled in the antibiotic suppression arms did not tolerate the antibiotics (gastrointestinal distress) and were thus excluded from the study, and 2 subjects admitting noncompliance with daily L-carnitine supplementation were only included in baseline challenge studies. Thus, $n = 10$ vegans/vegetarians and $n = 20$ omnivorous subjects were included in the studies (see Supplemental Table 2 for baseline data). Baseline data for 3 omnivorous subjects were unavailable. Six of 7 vegans/vegetarians and 7 of 8 omnivores enrolled in the L-carnitine supplementation and challenge studies were used in the exploratory fecal metabolite studies based on availability of fecal samples. A second group of self-selected healthy volunteers on the Procter & Gamble campus (all omnivores) gave consent and donated fecal samples for microbial culture and biochemical analyses.

Human L-carnitine and d_9 - γ BB challenge test. Adults who had given consent performed a 12-hour fast overnight before performing the L-carnitine challenge test, which involved a baseline blood sample and then oral consumption (t_0 at time of initial ingestion) of capsules containing 250 mg d_3 -L-carnitine (under investigational new drug exemption). In a second group of subjects, a d_9 - γ BB challenge was performed with 250 mg d_9 - γ BB. Following the baseline blood draw and ingestion of the capsule of isotope tracer, sequential venous serial blood draws

were performed at noted time points for the determination of d_9 - γ BB metabolites. Urine was collected as a spot baseline sample and a sample after 24-hour challenge. After completion of the initial L-carnitine or γ BB challenge (baseline or visit 1), an ensuing week-long treatment of oral antibiotics (7) was given to suppress intestinal microbiota, and the challenge (d_3 -L-carnitine or d_9 - γ BB) was then repeated (visit 2).

Synthesis of d_3 -L-carnitine and d_9 - γ BB. Synthesis of d_3 -L-carnitine was prepared as previously described (6, 60). Briefly, L-norcarnitine (3-hydroxy-4-dimethylaminobutyric acid) was prepared from L-carnitine (Chem Impex International) with thiophenol (Sigma-Aldrich) in *N,N*-dimethylaminoethanol (Sigma-Aldrich) and then was converted to its sodium salt with sodium hydroxide by the method of Colucci et al. (61). Sodium L-norcarnitine was recrystallized from ethanol and ethyl acetate before conversion to d_3 -L-carnitine. Some d_3 -L-carnitine was synthesized by dissolving sodium L-norcarnitine in methanol and reacting it with d_3 -methyl iodide (Cambridge Isotope Laboratories) in the presence of potassium hydrogen carbonate to give d_3 -L-carnitine per Chen and Benoiton (62). d_3 -L-carnitine was isolated by silica gel column rinsing with methanol elution. The product was dried via azeotropic distillation of absolute ethanol and subsequently recrystallized from ethanol and acetone. The crystalline product was dried over P_2O_5 in vacuo and stored in a desiccator by refrigeration. Structural analysis of d_3 -L-carnitine was confirmed by both high-resolution MS and NMR, and found to be more than 98% pure by LC-MS, NMR, and TLC.

Synthetic d_9 - γ BB was prepared as a chloride salt from γ -aminobutyric acid in methanol with potassium hydrogen carbonate and d_3 -methyl iodide, as previously described (26). Briefly, (3-carboxypropyl)trimethyl(d_3)ammonium chloride (d_9 -butyrobetaine chloride, d_9 -BB) was prepared from γ -aminobutyric acid in methanol with potassium hydrogen carbonate and d_3 -methyl iodide (all from Sigma-Aldrich) (63). The reaction lasted 72 hours and was transferred onto a bed of silica gel (pores 60 Å, particles 40–60 μ m; Agela Technologies) and equilibrated and washed in methanol. Rotary evaporation was used to yield the crude product, which was dissolved in water and titrated to pH 7.2. Further water was azeotropically removed by rotary evaporation with ethanol. The product was dissolved in absolute ethanol, filtered, concentrated to dryness by rotary evaporation, and dissolved in hydrochloric acid. The product was redissolved in a minimal amount of methanol and treated with 5 volumes of acetone to precipitate crystal formation. The crystals were filtered under suction, and dried under vacuum at 60°C. All reagents were obtained from Sigma-Aldrich unless otherwise indicated. Structural analysis of d_9 - γ BB was confirmed by both high-resolution MS and multinuclear NMR, and found to be more than 98% pure by LC-MS, NMR, and TLC.

Isolation and characterization of microorganisms involved in L-carnitine catabolism. Fecal samples were collected from volunteer donors who gave informed consent. Subject privacy and confidentiality of identifiable information were protected. Immediately after fecal samples were collected, glycerol stock suspensions were generated and sample aliquots snap-frozen in liquid nitrogen and maintained at -80°C until use. Thawed fecal slurry (200 mg feces) was suspended in 2 ml M9 minimal medium, with vigorous mixing to homogenize sample and break any clumps. The fecal slurry was centrifuged at low speed to eliminate large particulate matter and then at high speed for 2 minutes to harvest cells. Cells were then washed twice with M9, filtered through a 35- μ m cell strainer, and diluted 1:100 in enrichment media (brain heart infusion [BHI] media supplemented with 500 μ M

L-carnitine). Cultures were grown under anaerobic conditions at 37°C for 12 days, diluting 1:100 in enrichment media every 2 days. After 12 days in culture, enriched communities were spread and plated in BHI plates supplemented with 500 μM L-carnitine. To reduce the complexity of the microbial community, single colonies, groups of 2–3 colonies, and groups of 4+ colonies totaling 768 cultures were then picked and inoculated into 1 ml of BHI containing 50 μM d₃-L-carnitine. After 24 hours at 37°C under anaerobic conditions, a sample of culture supernatant was collected and quenched by addition of formic acid to a final concentration of 0.1%. The amount of d₃-TMA produced was determined by LC-MS/MS. The top d₃-TMA-producing well was selected and replated, repeating the community simplification steps as described above. Once the top d₃-TMA-producing community was identified, the cells were spread and plated. Single colonies were isolated and identified by matrix-assisted laser desorption/ionization time-of-flight mass spectrometry (MALDI-TOF MS) using a Biotyper System (Bruker Daltonics Inc.) (64). Isolates with similar high-confidence identification were pooled into 4 separate species pools, SP1 through SP4. All isolates with no reliable identification by MS were pooled into a fifth pool, SP5, and subsequently identified by 16S-rRNA sequence analysis (AccuGENX-ID, Accugenix).

Single microbial isolates or pools of isolates were evaluated alone or in combination for their ability to catabolize compounds of the L-carnitine pathway. Starter cultures were grown in BHI for 24 hours at 37°C under anaerobic conditions. Cells were harvested by centrifugation and washed in M9 minimal medium. After washing, cells were resuspended in M9 supplemented with 50 μM d₃-L-carnitine or 50 μM d₃-γBB as indicated. For kinetic experiments with fecal communities, fecal slurries prepared as described above were used instead of starter cultures. Reactions were allowed to proceed for up to 32 hours at 37°C under anaerobic conditions, as indicated. Samples of culture supernatant quenched by addition of formic acid to a final concentration of 0.1% were analyzed by LC-MS/MS to quantify concentrations of d₃-TMA, d₃-L-carnitine, and/or d₃-γBB.

Human fecal polymicrobial incubation with deuterium-labeled L-carnitine and γBB. Human fecal samples were collected, snap-frozen in glycerol stock using liquid nitrogen, and maintained at –80°C until use. Feces (50 mg) was incubated with 1 ml reaction solution containing 150 mM d₃-L-carnitine, d₃-L-carnitine, or d₃-γBB as indicated within 10 mM HEPES, pH 7.4, in a gas-tight reaction vial under anaerobic (Argon) conditions at 37°C. Reactions were stopped 16 hours later by addition of formic acid to a final concentration of 0.1%. The products were determined by LC-MS/MS with d₄-choline and ¹³C,¹⁵N-TMA added as internal standards and normalized to mass of fecal content.

General statistics. A Mann-Whitney (Wilcoxon rank sum test) 2-tailed nonparametric test or a Pearson χ^2 test was used to compare group means and AUCs. A Wilcoxon matched-pairs test or a zero-inflated linear mixed-effects model was used to assess linked human and baseline treatment effects as deemed appropriate. A repeated-measures 1-way ANOVA test was used to assess differences of baseline plasma concentrations of γBB and TMAO between multiple visits. For all analyses a *P* value less than 0.05 was considered significant. All

data were analyzed using R software version 3.43, JMP version 14, or Prism (GraphPad Software).

Study approval. All clinical investigations were conducted according to Declaration of Helsinki principles. All research subject gave written information consent prior to inclusion in the study, and all human studies were approved by the Cleveland Clinic institutional review board. Participant samples were identified by code number only.

Author contributions

RAK helped conceive, design, perform, and organize many of the experiments, assisted in statistical analyses, and assisted in drafting of the manuscript. BRLG conducted microbial isolation and characterization experiments. ZW assisted with mass spectrometry and human fecal polymicrobial culture enzyme assays. BSL, DB, and XG synthesized and purified all heavy isotope-labeled compounds used in the studies. MFC and DBC performed kinetics polymicrobial studies. JK helped in recruitment and performance of the human L-carnitine and γBB challenge studies. HJD, EBB, XSL, XF, and MKC assisted with mass spectrometry analyses. YW and LL performed statistical analyses. JAD helped with study design. WHWT helped with human studies design and oversight. JCGG conceived and designed microbial isolation and characterization studies and helped draft the manuscript. SLH conceived the idea, helped design experiments, and helped draft the manuscript. All authors participated in critical review of the manuscript.

Acknowledgments

We thank L. Kerchenski and C. Stevenson for assistance in performing the clinical studies, and A. Pratt, S. Neale, M. Pepoy, B. Sullivan, and K. Ward for technical assistance with human specimen processing and routine clinical diagnostic testing. We thank the Cleveland Clinic Cardiology Fellowship Program for providing support from the Ralph C. Wilson Jr. Fellow Leadership Education endowment to RAK, and the Leonard Krieger Endowed Chair fund for partial support of SLH. Mass spectrometry studies were performed on instruments supported in part by a Center of Excellence Award by Shimadzu Inc. This work received funding from National Institutes of Health and Office of Dietary Supplements grants HL103866, HL126827 and DK106000, and the Leducq Foundation.

Address correspondence to: Stanley L. Hazen, Department of Cellular and Molecular Medicine, Lerner Research Institute, Cleveland Clinic, 9500 Euclid Avenue, mail code NC-10, Cleveland, Ohio 44195, USA. Phone: 216.445.9763; Email: hazens@ccf.org.

DB's present address is: Department of Diagnostic Radiology, Mayo Clinic, Rochester, Minnesota, USA.

MKC's present address is: Department of Vascular Medicine Institute, University of Pittsburgh School of Medicine, Pittsburgh, Pennsylvania, USA.

1. Brown JM, Hazen SL. The gut microbial endocrine organ: bacterially derived signals driving cardiometabolic diseases. *Annu Rev Med*. 2015;66:343–359.

2. Jonsson AL, Bäckhed F. Role of gut microbiota in atherosclerosis. *Nat Rev Cardiol*. 2017;14(2):79–87.
3. Blaser MJ. The microbiome revolution. *J Clin Invest*. 2014;124(10):4162–4165.

4. Zhu W, et al. Gut microbial metabolite TMAO enhances platelet hyperreactivity and thrombosis risk. *Cell*. 2016;165(1):111–124.
5. Wang Z, et al. Gut flora metabolism of phospho-

- tidylcholine promotes cardiovascular disease. *Nature*. 2011;472(7341):57–63.
6. Koeth RA, et al. Intestinal microbiota metabolism of L-carnitine, a nutrient in red meat, promotes atherosclerosis. *Nat Med*. 2013;19(5):576–585.
 7. Tang WH, et al. Intestinal microbial metabolism of phosphatidylcholine and cardiovascular risk. *N Engl J Med*. 2013;368(17):1575–1584.
 8. Bennett BJ, et al. Trimethylamine-N-oxide, a metabolite associated with atherosclerosis, exhibits complex genetic and dietary regulation. *Cell Metab*. 2013;17(1):49–60.
 9. Li XS, et al. Gut microbiota-dependent trimethylamine N-oxide in acute coronary syndromes: a prognostic marker for incident cardiovascular events beyond traditional risk factors. *Eur Heart J*. 2017;38(11):814–824.
 10. Senthong V, et al. Intestinal microbiota-generated metabolite trimethylamine-N-oxide and 5-year mortality risk in stable coronary artery disease: the contributory role of intestinal microbiota in a COURAGE-like patient cohort. *J Am Heart Assoc*. 2016;5(6):e002816.
 11. Shafi T, et al. Trimethylamine N-oxide and cardiovascular events in hemodialysis patients. *J Am Soc Nephrol*. 2017;28(1):321–331.
 12. Suzuki T, Heaney LM, Bhandari SS, Jones DJ, Ng LL. Trimethylamine N-oxide and prognosis in acute heart failure. *Heart*. 2016;102(11):841–848.
 13. Tang WH, et al. Gut microbiota-dependent trimethylamine N-oxide (TMAO) pathway contributes to both development of renal insufficiency and mortality risk in chronic kidney disease. *Circ Res*. 2015;116(3):448–455.
 14. Trøseid M, et al. Microbiota-dependent metabolite trimethylamine-N-oxide is associated with disease severity and survival of patients with chronic heart failure. *J Intern Med*. 2015;277(6):717–726.
 15. Gregory JC, et al. Transmission of atherosclerosis susceptibility with gut microbial transplantation. *J Biol Chem*. 2015;290(9):5647–5660.
 16. Organ CL, et al. Choline diet and its gut microbe-derived metabolite, trimethylamine N-oxide, exacerbate pressure overload-induced heart failure. *Circ Heart Fail*. 2016;9(1):e002314.
 17. Zhu W, Wang Z, Tang WHW, Hazen SL. Gut microbe-generated trimethylamine N-oxide from dietary choline is prothrombotic in subjects. *Circulation*. 2017;135(17):1671–1673.
 18. Mafune A, et al. Associations among serum trimethylamine-N-oxide (TMAO) levels, kidney function and infarcted coronary artery number in patients undergoing cardiovascular surgery: a cross-sectional study. *Clin Exp Nephrol*. 2016;20(5):731–739.
 19. Wang Z, et al. Non-lethal inhibition of gut microbial trimethylamine production for the treatment of atherosclerosis. *Cell*. 2015;163(7):1585–1595.
 20. Shih DM, et al. Flavin-containing monooxygenase 3 exerts broad effects on glucose and lipid metabolism and atherosclerosis. *J Lipid Res*. 2015;56(1):22–37.
 21. Miao J, et al. Flavin-containing monooxygenase 3 as a potential player in diabetes-associated atherosclerosis. *Nat Commun*. 2015;6:6498.
 22. Roberts AB, et al. Development of a gut microbe-targeted nonlethal therapeutic to inhibit thrombosis potential. *Nat Med*. 2018;24(9):1407–1417.
 23. Skye SM, et al. Microbial transplantation with human gut commensals containing CutC is sufficient to transmit enhanced platelet reactivity and thrombosis potential. *Circ Res*. 2018;123(10):1164–1176.
 24. Zhu W, et al. Flavin monooxygenase 3, the host hepatic enzyme in the metaorganismal trimethylamine N-oxide-generating pathway, modulates platelet responsiveness and thrombosis risk. *J Thromb Haemost*. 2018;16(9):1857–1872.
 25. Zhu Y, et al. Carnitine metabolism to trimethylamine by an unusual Rieske-type oxygenase from human microbiota. *Proc Natl Acad Sci U S A*. 2014;111(11):4268–4273.
 26. Koeth RA, et al. γ -Butyrobetaine is a proatherogenic intermediate in gut microbial metabolism of L-carnitine to TMAO. *Cell Metab*. 2014;20(5):799–812.
 27. Rath S, Heidrich B, Pieper DH, Vital M. Uncovering the trimethylamine-producing bacteria of the human gut microbiota. *Microbiome*. 2017;5(1):54.
 28. Pan A, et al. Red meat consumption and mortality: results from 2 prospective cohort studies. *Arch Intern Med*. 2012;172(7):555–563.
 29. Wang X, et al. Red and processed meat consumption and mortality: dose-response meta-analysis of prospective cohort studies. *Public Health Nutr*. 2016;19(5):893–905.
 30. Abete I, Romaguera D, Vieira AR, Lopez de Munain A, Norat T. Association between total, processed, red and white meat consumption and all-cause, CVD and IHD mortality: a meta-analysis of cohort studies. *Br J Nutr*. 2014;112(5):762–775.
 31. Alisson-Silva F, Kawanishi K, Varki A. Human risk of diseases associated with red meat intake: analysis of current theories and proposed role for metabolic incorporation of a non-human sialic acid. *Mol Aspects Med*. 2016;51:16–30.
 32. Rebouche CJ, Seim H. Carnitine metabolism and its regulation in microorganisms and mammals. *Annu Rev Nutr*. 1998;18:39–61.
 33. Lindstedt G. Hydroxylation of γ -butyrobetaine to carnitine in rat liver. *Biochemistry*. 1967;6(5):1271–1282.
 34. Rebouche CJ. Kinetics, pharmacokinetics, and regulation of L-carnitine and acetyl-L-carnitine metabolism. *Ann N Y Acad Sci*. 2004;1033:30–41.
 35. Romano KA, Vivas EI, Amador-Noguez D, Rey FE. Intestinal microbiota composition modulates choline bioavailability from diet and accumulation of the proatherogenic metabolite trimethylamine-N-oxide. *MBio*. 2015;6(2):e02481.
 36. Sogawa K, et al. Use of the MALDI BioTyper system with MALDI-TOF mass spectrometry for rapid identification of microorganisms. *Anal Bioanal Chem*. 2011;400(7):1905–1911.
 37. Bessis S, Ndongo S, Lagier JC, Fournier PE, Raoult D. “Emergencia timonensis,” a new bacterium isolated from the stool of a healthy patient. *New Microbes New Infect*. 2016;12:73–75.
 38. Rebouche CJ, Engel AG. Significance of renal γ -butyrobetaine hydroxylase for carnitine biosynthesis in man. *J Biol Chem*. 1980;255(18):8700–8705.
 39. Bremer J. Carnitine — metabolism and functions. *Physiol Rev*. 1983;63(4):1420–1480.
 40. Kleber HP. Bacterial carnitine metabolism. *FEMS Microbiol Lett*. 1997;147(1):1–9.
 41. Rebouche CJ, Chenard CA. Metabolic fate of dietary carnitine in human adults: identification and quantification of urinary and fecal metabolites. *J Nutr*. 1991;121(4):539–546.
 42. Kleber HP, Seim H, Aurich H, Strack E. Utilization of trimethylammonium-compounds by *Acinetobacter calcoaceticus*. *Arch Microbiol*. 1977;112(2):201–206.
 43. Rebouche CJ. Quantitative estimation of absorption and degradation of a carnitine supplement by human adults. *Metab Clin Exp*. 1991;40(12):1305–1310.
 44. Muegge BD, et al. Diet drives convergence in gut microbiome functions across mammalian phylogeny and within humans. *Science*. 2011;332(6032):970–974.
 45. Schiattarella GG, et al. Gut microbe-generated metabolite trimethylamine-N-oxide as cardiovascular risk biomarker: a systematic review and dose-response meta-analysis. *Eur Heart J*. 2017;38(39):2948–2956.
 46. Qj J, et al. Circulating trimethylamine N-oxide and the risk of cardiovascular diseases: a systematic review and meta-analysis of 11 prospective cohort studies. *J Cell Mol Med*. 2018;22(1):185–194.
 47. Heianza Y, Ma W, Manson JE, Rexrode KM, Qj L. Gut microbiota metabolites and risk of major adverse cardiovascular disease events and death: a systematic review and meta-analysis of prospective studies. *J Am Heart Assoc*. 2017;6(7):e004947.
 48. Barnett C, et al. Effect of L-carnitine supplementation on muscle and blood carnitine content and lactate accumulation during high-intensity sprint cycling. *Int J Sport Nutr*. 1994;4(3):280–288.
 49. Trappe SW, Costill DL, Goodpaster B, Vukovich MD, Fink WJ. The effects of L-carnitine supplementation on performance during interval swimming. *Int J Sports Med*. 1994;15(4):181–185.
 50. Vukovich MD, Costill DL, Fink WJ. Carnitine supplementation: effect on muscle carnitine and glycogen content during exercise. *Med Sci Sports Exerc*. 1994;26(9):1122–1129.
 51. Orer GE, Guzel NA. The effects of acute L-carnitine supplementation on endurance performance of athletes. *J Strength Cond Res*. 2014;28(2):514–519.
 52. Wall BT, Stephens FB, Constantin-Teodosiu D, Marimuthu K, Macdonald IA, Greenhaff PL. Chronic oral ingestion of L-carnitine and carbohydrate increases muscle carnitine content and alters muscle fuel metabolism during exercise in humans. *J Physiol (Lond)*. 2011;589(pt 4):963–973.
 53. Decombaz J, Deriaz O, Acheson K, Gmuender B, Jequier E. Effect of L-carnitine on submaximal exercise metabolism after depletion of muscle glycogen. *Med Sci Sports Exerc*. 1993;25(6):733–740.
 54. Pekala J, et al. L-carnitine — metabolic functions and meaning in humans life. *Curr Drug Metab*. 2011;12(7):667–678.
 55. Demarquoy J. Radioisotopic determination of L-carnitine content in foods commonly eaten in Western countries. *Food Chem*. 2004;86(1):137–142.
 56. Rigault C, Mazué F, Bernard A, Demarquoy J, Le Borgne F. Changes in L-carnitine content of fish and meat during domestic cooking. *Meat Sci*. 2008;78(3):331–335.

57. Lo WK, et al. Comparison of inverse and regular 2-pyridyl-1,2,3-triazole “click” complexes: structures, stability, electrochemical, and photophysical properties. *Inorg Chem*. 2015;54(4):1572-1587.
58. Morgun A, et al. Uncovering effects of antibiotics on the host and microbiota using transkingdom gene networks. *Gut*. 2015;64(11):1732-1743.
59. Wang Z, et al. Protein carbamylation links inflammation, smoking, uremia and atherogenesis. *Nat Med*. 2007;13(10):1176-1184.
60. Gandour RD, Colucci WJ, Stelly TC, Brady PS, Brady LJ. Active-site probes of carnitine acyltransferases. Inhibition of carnitine acetyltransferase by hemiacetylcarnitinium, a reaction intermediate analogue. *Biochem Biophys Res Commun*. 1986;138(2):735-741.
61. Colucci WJ, Turnbull SP, Gandour RD. Preparation of crystalline sodium norcarnitine: an easily handled precursor for the preparation of carnitine analogs and radiolabeled carnitine. *Anal Biochem*. 1987;162(2):459-462.
62. Chen FCM, Benoiton NL. A new method of quaternizing amines and its use in amino acid and peptide chemistry. *Can J Chem*. 1976;54(20):3310-3311.
63. Morano C, Zhang X, Fricker LD. Multiple isotopic labels for quantitative mass spectrometry. *Anal Chem*. 2008;80(23):9298-9309.
64. Seng P, et al. Ongoing revolution in bacteriology: routine identification of bacteria by matrix-assisted laser desorption ionization time-of-flight mass spectrometry. *Clin Infect Dis*. 2009;49(4):543-551.