

# Human Deficiency of the Eighth Component of Complement

## THE REQUIREMENT OF C8 FOR SERUM

## NEISSERIA GONORRHOEAE BACTERICIDAL ACTIVITY

B. H. PETERSEN, J. A. GRAHAM, and G. F. BROOKS

*From the Lilly Laboratory for Clinical Research and the Department of Medicine, Division of Infectious Diseases, Indiana University School of Medicine, Indianapolis, Indiana 46202*

**ABSTRACT** The serum of a 23-yr-old woman with prolonged disseminated gonococcal infection syndrome failed to normally promote hemolysis of sensitized sheep red blood cells (RBC). The patient's serum was deficient in the eighth component of complement (C8) as determined by functional assays, immunoelectrophoresis, and quantitative immunoprecipitation. Functional titers of each of her other complement components were normal. No serum inhibitors of C8 were detected. The patient's serum supported activation of both the classical and alternate complement pathways. Her fresh serum lacked any bactericidal activity against *Neisseria gonorrhoeae*, but addition of purified C8 or complement donor serum restored bactericidal activity as well as RBC hemolytic activity. Her serum gave normal opsonization of yeast particles and staphylococci and had normal capacity to coat sensitized RBC with C3 and C4 and to generate chemotactic activity. No defects were observed in the patient's blood coagulation mechanisms. Complement-mediated bacterial lysis may be important in human defense against bacteremic *Neisseria* infections.

### INTRODUCTION

Since the description of a genetically transmitted defect in the synthesis of the C1<sup>i</sup> inhibitor by Donaldson and Evans (1), human deficiencies or abnormalities in the function of each of the earlier acting components of complement have been reported (2, 3). Recently, re-

A preliminary report was presented at the American Federation for Clinical Research Meeting, 4 May 1975, in Atlantic City, N. J.

Received for publication 16 June 1975 and in revised form 19 September 1975.

<sup>1</sup>Nomenclature used for the classical complement pathway conforms with that agreed upon by the World Health Organization (*Bull. W. H. O.* 39: 935-938, 1968).

ports have described hereditary deficiencies in man of two of the later acting complement components, the sixth (4) and seventh (5, 6). The purpose of this report is to describe a hereditary deficiency in the eighth component of complement in a woman with a disseminated gonococcal infection (DGI)<sup>2</sup> and the possible relationship of this defect to her disseminated infection.

### PATIENT HISTORY

A 23-yr-old black woman was admitted to the hospital in October 1974, because of progressive polyarthralgia, malaise, and fever of 3½ wk duration. Initially, the patient had swelling, pain, and tenderness in the second through fifth metacarpal-phalangeal and proximal interphalangeal joints of her right hand. This persisted for 2-3 days and was associated with fever to 102°F; the symptoms abated with aspirin and bed rest treatment. Subsequently, she again had fever and myalgia with swelling and tenderness of both ankles. 3 days before admission her right knee became swollen and warm. The fever and malaise persisted. At the time of admission the angle and knee pain were severe and the patient could no longer walk without assistance. She did not note skin lesions and did not have a history of previous arthritis, Raynaud's phenomenon, or unusual bleeding.

In 1973, while 7 mo pregnant, the patient had painful swelling of her right arm. Pyuria was found and she was treated with oral ampicillin. A cervical culture done at the time of that examination yielded *Neisseria gonorrhoeae*. It was not determined if she had DGI.

The patient had previous hospitalizations including two for delivery by cesarean section. An umbilical herniorrhaphy was done at age 1 and a tonsillectomy and adenoidec-

<sup>2</sup>Abbreviations used in this paper: Cd, complement donor serum; CFU, colony-forming unit; CH<sub>50</sub>, hemolytic whole complement assay; C3PA, C3 proactivator; DGI, disseminated gonococcal infection; EA, hemolysin-sensitized sheep erythrocyte; GCI, GC agar base with IsovitaleX; Gl-GVB, glucose-gelatin Veronal buffer; MBH, Mueller-Hinton broth; PBS, phosphate-buffered saline; PMN, polymorphonuclear leukocyte; SRBC, sheep red blood cell.

tomy at age 5. At age 14 she had cardiac catheterization for evaluation of a possibly significant systolic murmur. Chest roentgenogram, electrocardiogram, echocardiogram, cineangiography, and cardiac catheterization data were all borderline normal or within normal limits. Subsequent evaluations have not disclosed evidence of heart disease. Pyelonephritis and iron deficiency anemia were diagnosed in June 1973; her serum iron was 49  $\mu\text{g/ml}$  and the total iron binding capacity was 621  $\mu\text{g/ml}$ , with 8% saturation. She was given oral iron therapy. Her other medications were birth control pills and aspirin.

The patient's father is healthy. Her mother has diabetes, hypertension, and heart disease. Two stepbrothers and four stepsisters, ages 9-21 yr, are healthy. The patient has two children with different fathers. The 4-yr-old daughter is healthy, but the 1-yr-old son had staphylococcal osteomyelitis.

On physical examination her temperature was 101.8°F; the pulse was 88 per min and regular; her blood pressure was 110/80 mm Hg. She was well developed and well nourished, but uncomfortable. Her right knee was slightly swollen, warm, and tender to palpation; however, fluid in the joint was not detectable. No skin lesions were present. Her genitalia and pelvis were normal to examination. Esotropia was present on the left, but extraocular muscle motion was intact. A grade 2 of 6 systolic murmur and an S3 gallop were heard along the left sternal border. The remainder of her physical examination was normal.

Her hematocrit was 34% and white blood cell count 7,800/mm<sup>3</sup>. The urinalysis, serum electrolytes, serum glutamic oxalocetic transaminase, and alkaline phosphatase, glucose, protein, bilirubin, and uric acid were within normal limits. An electrocardiogram and chest roentgenogram were normal. The right knee roentgenogram showed possible soft tissue swelling. A tuberculosis skin test was negative and a mumps skin test was positive. Other tests included: Venereal Disease Research Laboratory test, negative; hepatitis-associated antibody, negative; rheumatoid factor, negative; antistreptolysin O titer, 166 Todd U; blood type A, Rh positive; and rubella titer (in 1973), 1:160. An initial impression of possible systemic lupus erythematosus results in analysis for her hemolytic complement level; her serum had no red blood cell hemolytic complement activity, precipitating the investigation reported here.

A blood culture and cervical culture taken at admission were positive for *N. gonorrhoeae*, confirming the diagnosis of DGI. Therapy was 12 million U of penicillin intravenously per day for 4 days followed by oral ampicillin for 7 days. After 1 day of penicillin therapy the patient was asymptomatic. Follow-up genital, rectal, nasopharyngeal, and blood cultures were negative for *N. gonorrhoeae*.

In April 1975, the patient was again admitted to the hospital with a 3-day history of fever with swelling and pain in her right elbow and right knee. Skin lesions typical of DGI were noted on a hand and a foot. A cervical culture was positive for *N. gonorrhoeae*, but blood cultures were negative. The patient had remarkable improvement with intravenous penicillin therapy.

The patient has had two episodes of documented DGI and a third episode of possible DGI.

## METHODS

*Sera.* Human sera used in these studies were obtained from blood drawn by venipuncture. Sera used for complement assays were either freshly drawn or freshly frozen in aliquots at -70°C. Samples were discarded after thaw-

ing. Normal sera were obtained and stored in a similar manner. Complement donor serum (Cd) used in bactericidal assays was obtained from a 15-yr-old boy with familial hypogammaglobulinemia. He had no demonstrable antibodies to *N. gonorrhoeae* and a serum CH<sub>50</sub> of 50 U. Sera from four normal persons were pooled and used as a reference serum in the hemolytic assays.

Guinea pig serum was obtained from Cordis Laboratories, Miami, Fla., stored in aliquots at -70°C, and discarded after thawing.

*Specific antisera.* Anti-human C3 and anti-human C4 antisera prepared in rabbits was obtained from Behring Diagnostics, Somerville, N. J. C3 proactivator (C3PA) levels were determined by single radial diffusion using plates obtained from Behring Diagnostics. Monospecific goat anti-human C8 antisera was provided by Dr. H. J. Müller-Eberhard, Scripps Clinic and Research Foundation, La Jolla, Calif. Rabbit antisera (hemolysin) to sheep erythrocytes was purchased from Grand Island Biological Co., Grand Island, N. Y.

*Sheep red blood cells (SRBC).* SRBC were obtained from Colorado Serum Co., Denver, Colo., preserved in modified Alserver's solution. Cells were used within 5 days of receipt. Before use cells were washed three times in 20 vol of 5 mM phosphate-buffered saline (PBS), pH 7.2-7.4.

*Complement assays.* Hemolytic whole complement assays (CH<sub>50</sub>) were performed as described by Taliaferro and Taliaferro (7) with SRBC sensitized with hemolysin (EA). Individual complement component titers (C1 through 9) were determined by the procedures of Nelson et al. (8) with modifications suggested by Cordis Laboratories. Reaction tubes were prepared containing a final volume of 2.5 ml of reactants, incubated, and the percent lysis determined with a Coleman Jr. Spectrophotometer model 6/35 (Coleman Instruments Div., Perkin Elmer Corp., Oak Brook, Ill.) at 415 nm. The CH<sub>50</sub> titer was read as the reciprocal of the dilution giving 50% lysis. Functionally pure complement components (C1-9) and cellular intermediates were obtained from Cordis Laboratories. Human or guinea pig serum used to reconstitute the deficient serum was diluted 1:20 in glucose-gelatin Veronal buffer (GI-GVB) containing 0.01 M EDTA (Calbiochem, La Jolla, Calif.); 2 ml of 1% EA was added to 1 ml of serum, the mixture incubated 20 min at 30°C and 1 ml of EDTA-treated serum added. After incubation at 37°C for 30 min the degree of hemolysis was determined at a wave length of 541 nm in a Coleman Jr. Spectrophotometer.

Quantitative determination of C8 was done in the laboratory of Dr. H. J. Müller-Eberhard by single radial diffusion (9) with monospecific goat anti-human C8 antisera. Immunoelectrophoresis of normal and patient's serum was performed as described elsewhere (10).

*Activation of the alternate pathway.* Serum samples were divided into two 0.5-ml aliquots and inulin (Difco Laboratories, Detroit, Mich.), 1 mg, was added to one aliquot. The samples were then incubated for 30 min at 37°C and functional C3 and C4 titers were determined on both the inulin-treated and untreated samples.

*Complement coating of red blood cells.* Sensitized SRBC, 1 ml of a 1% suspension, were incubated with 1 ml of C8-deficient serum diluted 1/20 in GI-GVB for 30 min at 30°C, centrifuged, washed three times in 5 vol of PBS, and the cells resuspended in 1 ml of PBS. Coating with C3 or C4 was determined by an antiglobulin (Coombs) reaction with anti-human C3 and C4. Untreated EA and EA treated with heat-inactivated, 56°C for 30 min, C8-deficient serum served as controls.

**Phagocytosis of yeast cells.** Phagocytosis of unsensitized yeast particles was performed as described by Miller and Nilsson (11). Polymorphonuclear leukocyte (PMN) suspensions were prepared as described by Böyum (12).

**Chemotaxis.** The generation of chemotactic factors was studied by techniques similar to those as described by Leddy et al. (4) and Miller and Nilsson (11) with chambers described by Horwitz and Garrett (13). Chemotactic factors were generated by mixing 1 vol of undiluted serum with 4 vol of heat-aggregated IgG (65°C for 20 min), 1 mg/ml, and incubating the mixture at room temperature for 20 min. The lower chamber was then filled with the chemotactic factor and the upper chamber was filled with 0.5 ml of PMN suspension. The chamber was incubated at 37°C for 90 min, the filter removed and stained and the average number of PMN per high-power field determined. Only PMN which had migrated through the filter were counted. A minimum of 10 fields were counted.

**Coagulation studies.** Activated partial thromboplastin time was performed as described by Davidsohn and Henry (14). Activated clotting time was determined by the method of Hattersley (15). Recalcification time was determined by the method described by Colman et al. (16).

**Isolation of *N. gonorrhoeae*.** *N. gonorrhoeae* in the patient's blood culture were subcultured once on GCI agar (GC agar base [Bioquest, Oxnard, Calif.] with IsovitaleX [Bioquest]) and incubated at 36.5°C in a 5% CO<sub>2</sub> incubator. The organisms were then frozen at -70°C in small aliquots in a mixture of equal parts of MHB (Mueller-Hinton Broth [Bioquest]) and defibrinated calf serum (Grand Island Biological Co.). *N. gonorrhoeae* to be used for the bactericidal assays were grown for 16 h on GCI agar after inoculation from the frozen specimens or after subculture of type 1 gonococcal colonies (17).

***N. gonorrhoeae* bactericidal assay.** Serum bactericidal antibody activity was assayed in a buffered medium containing medium 199 (obtained 10× concentrated, Microbiological Associates, Bethesda, Md.); 0.025 M *N*-2-hydroxyethylpiperazine-*N'*-2-ethane sulfonic acid buffer, pH 7.4 (Microbiological Associates); and 0.5% bovine serum albumin (Miles Laboratories, Inc., Kankakee, Ill.). *N. gonorrhoeae* were gently taken from the agar surface, placed into the buffered medium, and adjusted to an OD of 0.12 (Coleman Jr. Spectrophotometer) which corresponded to 10<sup>8</sup> colony-forming units (CFU) per ml. The bactericidal reaction mixture contained: 0.1 ml of the *N. gonorrhoeae* inoculum, 0.1 ml of the patient's freshly frozen serum or heated serum (56°C, 30 min), 0.2 ml of Cd (10 CH<sub>50</sub> U), and sufficient buffered medium to make a final volume of 1.0 ml. Cd containing 10 CH<sub>50</sub> U, when added to heated serum, had previously been shown to reconstitute the serum gonococcal bactericidal activity.<sup>3</sup> In experiments using functionally pure C8 in place of Cd serum 10,000 U of C8 in 0.15 M NaCl was added to the reaction mixture with 2× concentrated buffered medium, yielding a final concentration of buffered medium equivalent to the standard assay mixture. The bactericidal assay reaction mixtures were incubated at 37°C in snap-cap plastic tubes (Falcon Plastics Div., Bioquest) on a rotating rack (Fisher Scientific Co., Pittsburgh, Pa.) at 20 rpm. At appropriate intervals 0.1-ml samples were removed and serially diluted in MHB, plated on GCI agar, and incubated at 36.5°C overnight in 5% CO<sub>2</sub> for CFU determinations.

**Opsonization, phagocytosis, and killing of staphylococcus.** The staphylococcus opsonization experiments were done with

modifications of the techniques of Klebanoff (18, 19). Briefly, to prepare PMN 10-ml volumes of whole blood from normal donors were mixed with 10-ml volumes of 2% dextran 250 (Pharmacia Fine Chemicals, Piscataway, N. J.) in physiological saline, pH 7.4. After sedimentation of the red blood cells for 20 min the supernates were collected and the white blood cells gently pelleted (150 g, 10 min). The white cells were gently washed with 0.87% ammonium chloride to lyse the remaining red cells, re-centrifuged, mixed with calcium-free Krebs-Ringer phosphate buffer, and the percent and absolute number of PMN enumerated.

*Staphylococcus aureus* 502A was grown overnight on agar containing 5% sheep blood. Growth from several colonies was transferred to MHB and growth was continued for 3 h in a shaker water bath (37°C, 90 oscillations/min). The bacteria were sedimented by centrifugation, washed twice with sterile water, and resuspended in sterile water at a concentration of about 10<sup>8</sup> CFU per ml.

The complete reaction mixture contained about 10<sup>7</sup> CFU of staphylococcus 502A, 0.2 ml of the patient's freshly frozen serum, 2×10<sup>7</sup> PMN cells, and sufficient buffer with 0.1 M glucose to make a final volume of 1.0 ml. Controls included tubes containing the patient's serum heated (56°, 30 min), freshly frozen serum from a normal donor with type AB, Rh-positive blood, and PMN, each alone and in combination.

## RESULTS

**Determination of C8 deficiency.** The initial whole complement assays (CH<sub>50</sub>) revealed that the patient's serum lacked any demonstrable hemolytic activity. The serum caused no hemolysis of EAC1, EAC4, or EAC1,4 cells, indicating that the deficiency was not in C1 or C4. Addition of EDTA-treated normal human or guinea pig serum to the patient's serum produced strong hemolysis of EA; addition of EDTA alone did not promote hemolysis. No hemolysis was observed after the addition of functionally pure complement components C2-6. The capacity of the patient's serum to coat RBC with C3 and C4 was demonstrated by the agglutination of EA, after incubation with the patient's serum, with antisera monospecific for C3 and C4. These results indicated that the patient's serum contained functionally active C1 through C3 and was probably deficient in one of the later acting components. Heat-inactivated Cd serum failed to restore the bactericidal activity of the patient's serum. Analysis of the results suggested that the patient's serum might be deficient in the heat-labile component C8. The addition of 100 U of functionally pure C8, but not C9, restored the hemolytic activity of the patient's serum. Hemolysis of EA after the addition of C8 was dose related. The results of these assays expressed as a dose-response curve (Fig. 1) support a one-hit hypothesis (20) for C8. After the addition of a minimum of 100 U of C8 the CH<sub>50</sub> of the patient's serum was 57, which falls within the normal range (40-70 CH<sub>50</sub> U).

**Complement components assays.** Functional assays for each of the complement components in the serum of

<sup>3</sup> Brooks, G. F. Unpublished observations.

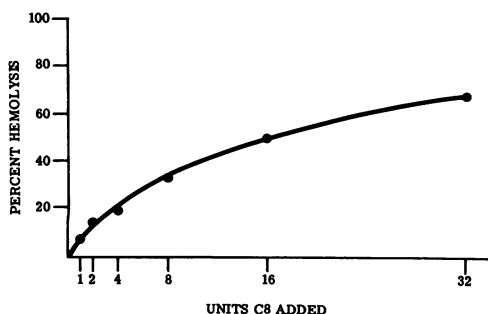

FIGURE 1 Dose-response curve after the addition of C8 to the patient's serum. Lysis of EA is expressed as percent hemolysis. Units of C8 are relative to the  $CH_{50}$  titer of the C8 determined by Cordis Laboratories.

the C8-deficient patient and those in the pool of normal sera were determined simultaneously. The results are shown in Table I. With the exception of the absence of C8 and a lower level of C9, all of the complement components in the serum of the C8-deficient patient were normal. The absence of any functional C8 activity demonstrated that the lack of serum hemolytic complement activity could be attributed to this deficiency.

Analysis of the patient's serum by single radial diffusion with monospecific goat anti-C8 antisera did not produce any visible precipitin line. Normal serum used as a reference contains approximately 80  $\mu\text{g}/\text{ml}$  of C8. After immunoelectrophoresis of the patient's serum, and normal serum, formation of a precipitin line with anti-C8 antisera was observed only with the normal serum.

The lack of C8 activity did not appear to be the result of the presence of an inhibitor. The  $CH_{50}$  activity

TABLE I  
Functional Assay of Individual Complement Components and Levels of C3 Proactivator\*

Component	C8-deficient serum	Reference serum†
	<i>CH<sub>50</sub> U/ml</i>	
C1	80,000	57,000
2	5,620	4,200
3	1,260	1,000
4	44,600	41,600
5	2,630	2,180
6	1,860	1,740
7	1,780	1,860
8	0	174,000
9	25,700	50,550
C3PA	20 mg/dl	12-30 mg/dl

\* C3 proactivator (C3PA) levels were measured by radial diffusion.

† Pool of serum from four individuals whose C1-9 values were within 1 SD of the mean values of normal subjects determined in our laboratory ( $n = 20$ ).

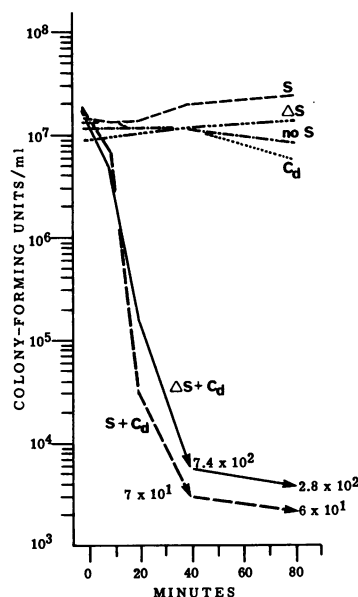

FIGURE 2 Bactericidal activity of C8-deficient serum (S) for *N. gonorrhoeae* isolated from the patient at admission. The addition of Cd containing 10  $CH_{50}$  U yielded bactericidal activity. The bactericidal activity of heated patient's serum ( $\Delta S$ ) was also reconstituted by addition of Cd.

of normal serum was not altered after incubation with equal volumes of the patient's undiluted serum.

*Alternate pathway activation.* The alternate pathway was intact and functional. Normal levels of C3PA were present in the patient's serum (Table I). The incubation of the patient's serum with inulin reduced the functional C3  $CH_{50}$  titer in the patient's serum from 1,200 to 600 U and in the normal control from 850 to 410 U while no decrease in C4 titers were observed.

*Bactericidal activity of C8-deficient serum.* The patient's serum was not observed to possess any bactericidal activity against *N. gonorrhoeae* either after the initial subculture or after selective subculture of colony type 1 or 3 cells. However, the addition of Cd containing 10  $CH_{50}$  U to the patient's freshly frozen serum or heated serum reconstituted the bactericidal activity (Fig. 2). The reconstituted serum yielded a 10,000-fold or greater reduction in CFU regardless of the number of prior subcultures or *N. gonorrhoeae* colony type. Neither the patient's freshly frozen serum, heated serum, nor the Cd serum had any bactericidal activity. The addition of functionally pure C8, in a concentration equivalent to 100,000 U/ml of serum, to the patient's freshly frozen serum restored serum bactericidal activity (Fig. 3). Addition of functionally pure complement components C2-7 did not reconstitute serum bactericidal activity.

*Opsonization.* The patient's serum promoted the phagocytosis of yeast cells as efficiently as normal serum

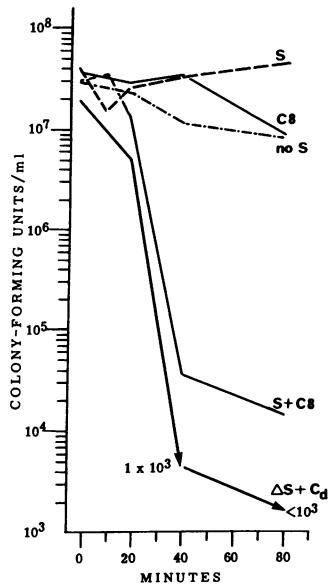

FIGURE 3 Restoration of bactericidal activity in C8-deficient serum (S) after the addition of purified C8 (C8) or Cd.

(Table II). The phagocytosis of *N. gonorrhoeae* by PMN was enhanced by the patient's serum (21). This activity was lost after heat inactivation (56°C for 30 min) of the patient's serum.

*Opsonization, phagocytosis, and killing of staphylococcus 502A.* The patient's serum yielded opsonization with resultant phagocytosis and killing of the test staphylococcus (Fig. 4). The results were similar to those obtained with the normal, AB, Rh-positive serum, much as previously reported (19). Serum alone, PMN alone, or heated serum with PMN did not yield a fall in the number of colony-forming units.

*Chemotactic activity.* The patient's serum was shown to generate chemotactic substances after incubation with heat-aggregated human IgG. The capacity to generate

TABLE II  
Phagocytosis of Yeast Cells

Incubation time . . .	Yeast particles/PMN*		
	30 min	45 min	60 min
Serum from PMN donor	3.9	3.8	3.9
Normal serum	3.3	4.1	4.3
C8-deficient serum	3.0	4.4	3.7

Yeast cells were incubated with normal or patient serum for 30 min at 37°C, washed, and added to the PMN suspension. The mixture was incubated at 37°C and aliquots removed at the times indicated.

\* Results are in terms of average number of yeast cells ingested by PMNs.

TABLE III  
Generation of Chemotactic Activity for Human PMN in C8-Deficient Serum Incubated with Heat-Aggregated Human IgG (Hu IgG)

Generating agent	PMN/HPF*	
	C8-deficient serum	Normal serum†
Aggregated Hu IgG	3.3	3.7
Buffer control	0	0.1

\* Average number of cells per high-power field for 10 random fields.

† Pool from four normal donors.

chemotactic substances was similar to that observed with normal serum. The results are summarized in Table III.

*Coagulation studies.* The kaolin-activated clotting time and activated partial prothrombin clotting time were normal. The recalcification time of plasma collected in siliconized glassware showed a significant shortening. After contact with kaolin the *n*-tosyl-L-arginine methyl esterase activity generated was within normal limits. These findings provided evidence that contact activation of the intrinsic pathway of blood coagulation as well as generation of kallikrein mediated by activated Hageman factor were intact in the C8-deficient patient.

*Family studies.* The family pedigree is shown in Fig. 5. The CH<sub>50</sub>, C8 functional titers, and C8 levels determined by radial diffusion are listed in Table IV. The proband (II-2) lacks C8 while her parents (I-1, 2) and children (III-1, 2) have about one-half normal levels of C8. There was no known consanguineous marriage in the three generations preceding the proband.

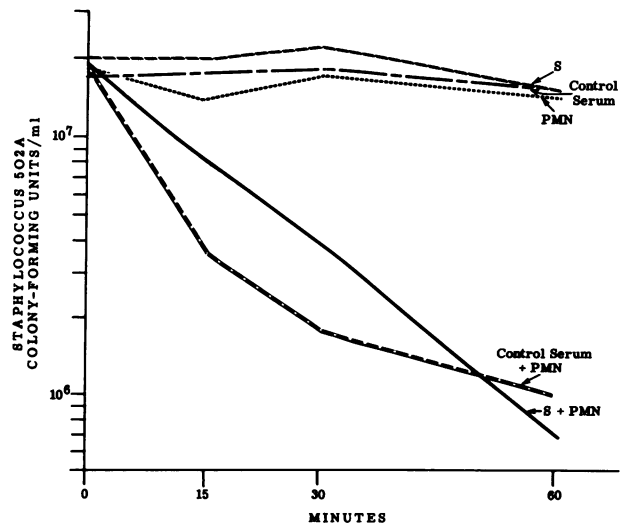

FIGURE 4 Opsonization of staphylococcus 502A by C8-deficient serum (S). Serum from a normal person with type AB, Rh-positive blood served as a control.

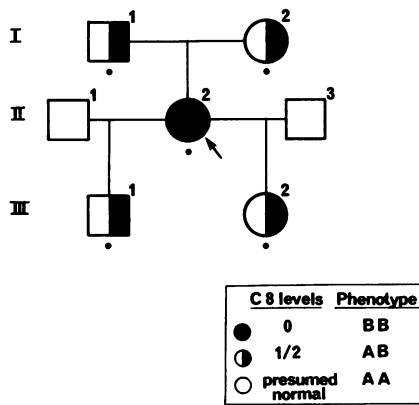

FIGURE 5 Pedigree of family with C8 deficiency. The proband is marked with an arrow. A dot below the symbol indicates the individual's serum was tested.

## DISCUSSION

The presence of hereditary deficiencies in the complement system of man has provided opportunities to better evaluate the role of complement *in vivo*. In this paper we have presented evidence of the discovery of a patient with a deficiency of the eighth component of complement. The patient's serum has no detectable functionally active or immunologically reactive C8.

Activation of complement components C1 through C7 via the classical pathway or through alternate pathway activation of C3 is a complex process with multiple biologically functional interrelationships (22). The absence of C8 does not appear to modify most of these biological effects as evidenced by normal activation in our patient's serum of the classical and alternate pathways, generation of opsonic and chemotactic activity, and normal coagulation. It appears from these studies that the key, if not only, role of C8 in man is the production of complement-mediated membrane damage; only a few molecules of C8 are required for red cell lysis (23).

The absence of C8 in the proband's serum indicates she is homozygous for C8 deficiency since approximately half-normal C8 levels are present in her parents' and children's sera, demonstrating that they are obligate heterozygotes (Fig. 5). The fathers of the proband's children are presumed to be homozygous for the normal C8 alleles. These results are consistent with the interpretation that C8 deficiency is genetically transmitted as part of the autosomal codominant system. We suggest that the locus be named "C8." Then the homozygous deficiency phenotype would be designated "C8 BB," the heterozygous phenotype "C8 AB," and the normal homozygous phenotype "C8 AA."

Deficiencies in the earlier acting components, C1 through C5, and in the inhibitors of the human comple-

TABLE IV  
Whole Complement and C8 Levels of the C8-Deficient Patient,  
Her Parents, and Her Children

Family member	Whole complement		C8
	CH <sub>50</sub> U/ml	Functional C8	
I-1	71	95,000	~40
I-2	65	92,000	~40
II-2 (proband)	0	0	0
III-1	33	97,000	~40
III-2	50	100,000	~40
Reference serum	50	174,000	80

ment system have been associated with a variety of clinically apparent diseases (2). Patients with C3 deficiency or abnormalities and patients with C5 abnormalities are known to be susceptible to gram-negative infections (3, 11, 24, 25). One C3-deficient patient had two hospitalizations for meningococcal meningitis (24) while two patients with C3 abnormalities had either meningococcal bacteremia or meningitis (25, 26). Patients with C3 abnormalities could have increased susceptibility to infection because of the failure of their sera to support opsonization (27, 28). However, the meningococcal infections may also have been associated with lack of a functional complement-mediated bactericidal system. The patients with C5 dysfunction had normal hemolytic complement levels and would presumably have normal complement-mediated bacterial lysis (11). Their susceptibility to infection may have resulted from an altered capacity to opsonize as mediated through C5 enhancement of C3 opsonization (11). Patients deficient in the earlier acting components (C1, C4, C2) are presumed to be protected from gram-negative infections through activation of the alternate pathway (28-31).

Meningococcal bacteremia or meningitis is fortunately a relatively infrequent complication of the nasopharyngeal infection with *Neisseria meningitidis*. Persons may be uniquely susceptible to meningococcal meningitis because of a selective deficiency of antibodies or because they do not develop antibodies to *N. meningitidis* (32, 33). Certainly, a functional serum meningococcal bactericidal antibody system is important in protection against *N. meningitidis* bacteremia and meningitis (32). It is likely that a similar mechanism exists for protection against *N. gonorrhoeae* bacteremia.

We have learned of five patients with deficiencies or abnormalities of the later acting components of complement. Neither of the C7-deficient persons had repeated severe infections (5, 6). A woman with C6 deficiency had two documented episodes of DGI but no history of other recurrent infections. A child with C6 deficiency

had repeated episodes of *N. meningitidis* infections.<sup>4</sup> Our patient with C8 deficiency has had two, possibly three, episodes of DGI.

The association of bacteremic *Neisseria* infections, C6, C8, or bactericidal antibody deficiencies is very strong (4, 32, 33). While there is no definitive information on the importance of an intact complement or bactericidal antibody system in protection against *N. gonorrhoeae* bacteremia the two known sexually-active adults with C6 or C8 deficiency had repeated gonococcal bacteremia. The 6-yr-old child with C6 deficiency had repeated *N. meningitidis* bacteremia and probably had not been exposed to *N. gonorrhoeae*. DGI can mimic diseases such as rheumatoid arthritis or systemic lupus erythematosus, where physicians might frequently request complement evaluations. Regardless, the finding of patients with complement or antibody deficiency, nonfunctional bactericidal systems, and bacteremic *Neisseria* infections indicates that serum bactericidal function is important in protection against *N. meningitidis* and *N. gonorrhoeae* bacteremia.

A possible role for opsonic antibodies in protection against DGI is not clear. The importance of *N. gonorrhoeae* pili or other gonococcal cell surface antiphagocytic substances has yet to be clarified (34-38). Regardless, opsonization with phagocytosis may be of secondary importance compared to protective serum bactericidal mechanisms. Our patient had a positive blood culture for *N. gonorrhoeae* after 3½ wk of DGI syndrome. It is very unusual for DGI patients to have positive blood cultures after the first 2 or 3 days of illness (39). Further, serum from her blood specimen which was culture positive for *N. gonorrhoeae* had opsonic activity, but her bactericidal system was not functional and she had a positive blood culture—again highlighting the importance of a bactericidal mechanism in protection against DGI.

In summary, the results of these studies suggest the major if not singular role of C8 in the human complement system is to promote complement-associated membrane damage. It appears this lytic activity may be important for adequate host resistance to infection by organisms of the genus *Neisseria*.

#### ACKNOWLEDGMENTS

The authors wish to thank Dr. H. J. Müller-Eberhard for the C8 determinations, Dr. N. Bang for the coagulation studies, and Dr. D. Merritt for his guidance on the family studies and for their helpful suggestions. Our thanks also to Barbara Edmonds, Patricia Miller, Janet Day, and Lewis Truex for their able technical assistance and to Beverly Vancil for the preparation of the manuscript.

This work was supported in part by contract PHS 21-73-532 from the Center for Disease Control.

<sup>4</sup>Gewurz, A., D. Lim, M. Ghaze, and T. F. Lint. *Clin. Res.* 23: 532A. (Abstr.)

#### REFERENCES

1. Donaldson, V. H., and R. R. Evans. 1963. A biochemical abnormality in hereditary angioneurotic edema. Absence of serum inhibitor of C'1-esterase. *Am. J. Med.* 35: 37-44.
2. Alper, C. A., and F. S. Rosen. 1974. The role of complement *in vivo* as revealed by genetic defects. In *Progress in Immunology*. II. L. Brent and J. Holborow, editors. North-Holland Publishing Co., Amsterdam. 1: 201-208.
3. Polley, M. J., and A. G. Bearn. 1975. Genetic aspects of diseases of complement: an explosion. *Am. J. Med.* 58: 105-111.
4. Leddy, J. P., M. M. Frank, T. Gaither, J. Baum, and M. R. Klemperer. 1974. Hereditary deficiency of the sixth component of complement in man. I. Immunochemical, biologic, and family studies. *J. Clin. Invest.* 53: 544-553.
5. Wellek, B., and W. Opferkuch. 1975. A case of deficiency of the seventh component of complement in man. Biological properties of a C7-deficient serum and description on a C7-inactivating principle. *Clin. Exp. Immunol.* 19: 223-235.
6. Boyer, J. T., E. P. Gall, M. E. Norman, U. R. Nilsson, and T. S. Zimmerman. 1975. Hereditary deficiency of the seventh component of complement. *J. Clin. Invest.* 56: 905-913.
7. Taliaferro, W. H., and L. G. Taliaferro. 1956. X-ray effects on hemolysin formation in rabbits with the spleen shielded or irradiated. *J. Infect. Dis.* 99: 109-128.
8. Nelson, R. A., Jr., J. Jensen, I. Gigli, and N. Tamura. 1966. Methods for the separation, purification and measurement of nine components of hemolytic complement in guinea-pig serum. *Immunochemistry.* 3: 111-135.
9. Mancini, G., A. O. Carbonara, and J. F. Heremans. 1965. Immunochemical quantitation of antigens by single radial immunodiffusion. *Immunochemistry.* 2: 235-254.
10. Scheidegger, J. J. 1955. Une micro-méthode de l'immuno-électrophorèse. *Int. Arch. Allergy Appl. Immunol.* 7: 103-110.
11. Miller, M. E., and U. R. Nilsson. 1970. A familial deficiency of the phagocytosis-enhancing activity of serum related to a dysfunction of the fifth component of complement (C5). *N. Engl. J. Med.* 282: 354-358.
12. Böyum, A. 1968. Isolation of mononuclear cells and granulocytes from human blood. Isolation of mononuclear cells by one centrifugation, and of granulocytes by combining centrifugation and sedimentation at 1 g. *Scand. J. Clin. Lab. Invest.* 21 Suppl. 97: 77-89.
13. Horwitz, D. A., and M. A. Garrett. 1971. Use of leukocyte chemotaxis *in vitro* to assay mediators generated by immune reactions. I. Quantitation of mononuclear and polymorphonuclear leukocyte chemotaxis with polycarbonate (Nucleopore) filters. *J. Immunol.* 106: 649-655.
14. Davidsohn, I., and J. B. Henry. 1969. *Todd-Sanford, Clinical Diagnosis by Laboratory Method*. W. B. Saunders Company, Philadelphia. 14th edition. 21.
15. Hattersley, P. G. 1966. Activated coagulation time of whole blood. *JAMA (J. Am. Med. Assoc.)*. 196: 436-440.
16. Colman, R. W., L. Mattler, and S. Sherry. 1969. Studies on the prekallikrein (kallikreinogen)-kallikrein enzyme system of human plasma. II. Evidence relating the kaolin-activated arginine esterase to plasma kallikrein. *J. Clin. Invest.* 48: 23-32.

17. Kellogg, D. S., Jr., W. L. Peacock, Jr., W. E. Deacon, L. Brown, and C. I. Pirkle. 1963. *Neisseria gonorrhoeae*. I. Virulence genetically linked to clonal variation. *J. Bacteriol.* **85**: 1274-1279.
18. Pincus, S. H., and S. J. Klebanoff. 1971. Quantitative leukocyte iodination. *N. Engl. J. Med.* **284**: 744-750.
19. Klebanoff, S. J., and C. B. Hamon. 1972. Role of myeloperoxidase-mediated antimicrobial systems in intact leukocytes. *J. Reticuloendothel. Soc.* **12**: 170-196.
20. Mayer, M. M. 1961. In Kabat and Mayer's Experimental Immunochemistry. 2nd edition. Charles C Thomas, Publisher, Springfield, Ill. 181-187.
21. Brooks, G. F., K. S. Israel, and B. H. Petersen. 1975. Serum bactericidal and opsonic antibodies in disseminated gonococcal infections. *Clin. Res.* **23**: 301A. (Abstr.)
22. Ruddy, S., I. Gigli, and K. F. Austen. 1972. The complement system of man (first of four parts). *N. Engl. J. Med.* **287**: 489-495.
23. Manni, J. A., and H. J. Müller-Eberhard. 1969. The eighth component of human complement (C8): isolation, characterization and hemolytic efficiency. *J. Exp. Med.* **130**: 1145-1160.
24. Alper, C. A., H. R. Colten, F. S. Rosen, A. R. Rabson, G. M. Macnab, and J. S. S. Gear. 1972. Homozygous deficiency of C3 in a patient with repeated infections. *Lancet.* **2**: 1179-1181.
25. Alper, C. A., N. Abramson, R. B. Johnston, Jr., J. H. Jandl, and F. S. Rosen. 1970. Increased susceptibility to infection associated with abnormalities of complement-mediated functions and of the third component of complement (C3). *N. Engl. J. Med.* **282**: 349-354.
26. Alper, C. A., K. J. Bloch, and F. S. Rosen. 1973. Increased susceptibility to infection in a patient with type II essential hypercatabolism of C3. *N. Engl. J. Med.* **288**: 601-606.
27. Gigli, I., and R. A. Nelson, Jr. 1968. Complement dependent immune phagocytosis. I. Requirements for C'1, C'4, C'2, C'3. *Exp. Cell Res.* **51**: 45-67.
28. Root, R. K., L. Ellman, and M. M. Frank. 1972. Bactericidal and opsonic properties of C4-deficient guinea pig serum. *J. Immunol.* **109**: 477-486.
29. Götze, O., and H. J. Müller-Eberhard. 1971. The C3 activator system: an alternate pathway of complement activation. *J. Exp. Med.* **134** (No. 3, Pt. 2): 90s-108s.
30. Pensky, J., C. F. Hinz, Jr., E. W. Todd, R. J. Wedgwood, J. T. Boyer, and I. H. Lepow. 1968. Properties of highly purified human properdin. *J. Immunol.* **100**: 142-158.
31. Jasin, H. E. 1972. Human heat labile opsonins: evidence for their mediation via the alternate pathway of complement activation. *J. Immunol.* **109**: 26-31.
32. Goldschneider, I., E. C. Gotschlich, and M. S. Artenstein. 1969. Human immunity to meningococcus. I. The role of humoral antibodies. *J. Exp. Med.* **129**: 1307-1326.
33. Fass, R. J., and S. Saslaw. 1972. Chronic meningococemia. Possible pathogenic role of IgM deficiency. *Arch. Intern. Med.* **130**: 943-946.
34. Gibbs, D. L., and R. B. Roberts. 1975. The interaction in vitro between human polymorphonuclear leukocytes and *Neisseria gonorrhoeae* cultivated in the chick embryo. *J. Exp. Med.* **141**: 155-171.
35. Swanson, J., E. Sparks, B. Zeligs, M. A. Siam, and C. Parrott. 1974. Studies on gonococcus infection. V. Observations on in vitro interactions of gonococci and human neutrophils. *Infect. Immun.* **10**: 633-644.
36. Swanson, J., and B. Zeligs. 1974. Studies on gonococcus infection. VI. Electron microscopic study on in vitro phagocytosis of gonococci by human leukocytes. *Infect. Immun.* **10**: 645-656.
37. Punsalang, A. P., Jr., and W. D. Sawyer. 1973. Role of pili in the virulence of *Neisseria gonorrhoeae*. *Infect. Immun.* **8**: 255-263.
38. Thongthai, C., and W. D. Sawyer. 1973. Studies on the virulence of *Neisseria gonorrhoeae*. I. Relation of colonial morphology and resistance to phagocytosis by polymorphonuclear leukocytes. *Infect. Immun.* **7**: 373-379.
39. Holmes, K. K., G. W. Counts, and H. N. Beaty. 1971. Disseminated gonococcal infection. *Ann. Intern. Med.* **74**: 979-993.